

**XIII. CROSS CONNECTION/BACKFLOW PREVENTION**

**I. INTRODUCTION**

In today's world of advanced technology most people assume that the water they drink is safe. Few people even give a second thought to the possibility that the public water system might be the carrier of dangerous -or even fatal- bacteria, chemical, or other agents harmful to the human body. The Charlotte Mecklenburg Utility Department has long been concerned about cross connections and potential backflow conditions in plumbing systems and in our drinking-water-supply distribution system.

Most of us realize that contaminated water can easily result in disease and death if it is consumed by humans or animals, but how many are aware that the danger is present with us every day. The more complex our industry and our technology becomes, the greater the potential hazard to human health. In spite of our advanced public water systems, the potential for contamination is growing. A Backflow Prevention and Cross Connection Control Program is essential to ensure that water remains as safe as it is when it leaves the treatment plant.

The Federal Safe Drinking Water Act mandates that the water supplier be responsible for the quality of the water to the service connection. Therefore CMUD and the City must take every precaution for protecting the public potable water from backflow of dangerous substances which would endanger the public health or physically damage the public water system.

The City of Charlotte Ordinance #3077 is an ordinance creating a new Article V to Chapter 23 of the Charlotte City Code, entitled "Backflow Prevention and Cross Connection Control". This requires all industrial, commercial and irrigation customers to install and maintain a backflow prevention assembly at every service connection to the CMUD system before any branching of the private system in accordance with CMUD specifications and standard details.

Charlotte City code requires backflow prevention assemblies to be installed and maintained by the customer. The customer is required to have assemblies tested annually by a CMUD approved certified tester. If the interruption of water service would have a critical impact on your operation, two backflow prevention assemblies must be installed in parallel in order for testing and maintenance requirements to be fulfilled. This will allow one assembly to continue providing water while the other is being tested or repaired.

Note that installation of a backflow prevention assembly will prevent release of on-site pressure to the utility water mains. Therefore, it is important that a temperature /pressure relief valve be properly installed and maintained to relieve any excessive increase in on-site pressure due to hot water heating systems or other activities.

## II. DEFINITIONS

**AIR GAP SEPARATION** - AN UNOBSTRUCTED VERTICAL DISTANCE THROUGH THE ATMOSPHERE BETWEEN THE LOWEST OPENING FROM ANY PIPE OR FAUCET SUPPLYING WATER FROM ANY SOURCE TO A TANK, PLUMBING FIXTURE, OR OTHER DEVICE AND THE FLOOD LEVEL RIM OF THE RECEPTACLE. AN APPROVED, AIR GAP SEPARATION SHALL BE AT LEAST DOUBLE THE DIAMETER OF THE SUPPLY PIPE. IN NO CASE SHALL THE AIR GAP SEPARATION BE LESS THE ONE (1) INCH. AN APPROVED, AIR GAP SEPARATION IS AN EFFECTIVE METHOD TO PREVENT BACKFLOW AND SHALL BE CONSIDERED AS A BACKFLOW PREVENTION ASSEMBLY.

**APPROVED** - IN REFERENCE TO BACKFLOW PREVENTION ASSEMBLIES OR METHODS, THOSE ASSEMBLIES OR METHODS WHICH HAVE BEEN ACCEPTED BY THE DIRECTOR AS AN EFFECTIVE DEVICE OR METHOD TO PREVENT BACKFLOW.

**ASSEMBLY** - BACKFLOW PREVENTION ASSEMBLY.

**AUXILIARY WATER SUPPLY** - ANY WATER SOURCE OTHER THAN THE PUBLIC WATER SYSTEM THAT IS USED IN CONJUNCTION WITH OR IS OTHERWISE AVAILABLE TO A PRIVATE WATER SYSTEM.

**BACKFLOW** - ANY FLOW OF WATER, OTHER LIQUID, GAS, OTHER SUBSTANCES, OR ANY COMBINATION THEREOF, INTO THE PUBLIC WATER SYSTEM FROM ANY SOURCE DUE TO AN UNPROTECTED CROSS-CONNECTION, BACK PRESSURE, BACK-SIPHONAGE, ANY COMBINATION THEREOF, OR ANY OTHER CAUSE; PROVIDED THAT, THE FOLLOWING ACTIVITIES BY CMUD SHALL NOT BE CONSTRUED AS BACKFLOW: THE INTRODUCTION OF RAW WATER INTO A CMUD WATER TREATMENT PLANT; THE TREATMENT OF SUCH WATER INTO A CMUD WATER TREATMENT PLANT; AND THE INTRODUCTION OF SUCH TREATED WATER BY CMUD INTO THE PUBLIC WATER SYSTEM.

**BACKFLOW PREVENTION ASSEMBLY** - AN EFFECTIVE DEVICE OR METHOD USED TO PREVENT BACKFLOW.

**BACK PRESSURE** - ANY PRESSURE ON WATER, OTHER LIQUID, GAS, OTHER SUBSTANCES, OR ANY COMBINATION THEREOF, IN A PRIVATE WATER SYSTEM THAT IS CONNECTED IN ANY MANNER TO THE PUBLIC WATER SYSTEM UNDER CIRCUMSTANCES IN WHICH SUCH PRESSURE IS GREATER THAN THE PRESSURE ON THE WATER IN THE PUBLIC WATER SYSTEM, SO THAT BACKFLOW MAY OCCUR.

**BACK-SIPHONAGE** - ANY CIRCUMSTANCE IN WHICH THE PRESSURE ON THE WATER IN THE PUBLIC WATER SYSTEM IS LESS THAN THE PRESSURE ON WATER, OTHER LIQUID, GAS, OTHER SUBSTANCES, OR ANY COMBINATION THEREOF IN A PRIVATE WATER SYSTEM THAT IS CONNECTED IN ANY MANNER TO THE PUBLIC WATER SYSTEM, SO THAT BACKFLOW MAY OCCUR.

**CERTIFIED TESTER** - AN INDIVIDUAL PERSON WHO HAS PROVEN HIS/HER COMPETENCY TO TEST, REPAIR, AND OVERHAUL BACKFLOW PREVENTION ASSEMBLIES OF ALL TYPES AND TO PREPARE REPORTS ON SUCH ASSEMBLIES, AS EVIDENCED BY SUCCESSFUL COMPLETION OF A TRAINING PROGRAM APPROVED BY THE DIRECTOR.

**CONTAMINATION** - THE IMPAIRMENT OF THE QUALITY OF WATER TO A DEGREE THAT HUMAN CONSUMPTION COULD RESULT IN POISONING OR THE SPREAD OF DISEASE.

**CONTAINMENT** - THE PREVENTION OF BACKFLOW FROM A PRIVATE WATER SYSTEM BY AN APPROVED, PROPERLY FUNCTIONING BACKFLOW PREVENTION ASSEMBLY WHICH IS INSTALLED, OPERATED AND MAINTAINED IN ACCORDANCE WITH THE PROVISIONS OF THIS ARTICLE.

**CROSS-CONNECTION CONTROL INSPECTOR** - AN EMPLOYEE OF THE CITY DESIGNATED BY THE DIRECTOR TO ADMINISTER AND ENFORCE THE BACKFLOW PREVENTION AND CROSS CONNECTION CONTROL ORDINANCE AND PROVISIONS OF THIS MANUAL.

**CUSTOMER** - ANY PERSON WHO IS CAPABLE OF RECEIVING WATER FROM THE PUBLIC WATER SYSTEM THROUGH THE CUSTOMER'S PRIVATE WATER SYSTEM, WITHOUT REGARD TO WHETHER CMUD IS AWARE OF THE EXISTENCE OF SUCH CUSTOMER. IF SUCH PERSON DOES NOT OWN THE PRIVATE WATER SYSTEM, "CUSTOMER" SHALL ALSO BE CONSTRUED TO INCLUDE THE PERSON WHO OWNS THE PRIVATE WATER SYSTEM.

**CUSTOMER'S PRIVATE WATER SYSTEM** - THE PRIVATE WATER SYSTEM THROUGH WHICH A CUSTOMER IS CAPABLE OF RECEIVING WATER FROM THE PUBLIC WATER SYSTEM.

**CUSTOMER'S POTABLE WATER SYSTEM** - THE PRIVATE WATER SYSTEM THROUGH WHICH A CUSTOMER RECEIVES WATER FROM THE PUBLIC WATER SYSTEM FOR PURPOSES OF HUMAN CONSUMPTION.

**DEGREE OF HAZARD** - THE EVALUATION OF A HAZARD WITHIN A PRIVATE WATER SYSTEM AS MODERATE OR HIGH.

**DOUBLE CHECK VALVE ASSEMBLY** - AN APPROVED, PROPERLY FUNCTIONING ASSEMBLY COMPOSED OF TWO, INDEPENDENTLY ACTING CHECK VALVES, INCLUDING TIGHTLY CLOSING SHUT-OFF VALVES ATTACHED AT EACH END OF THE ASSEMBLY AND FITTED WITH PROPERLY LOCATED TEST COCKS. THIS ASSEMBLY MAY ONLY BE USED TO PROTECT AGAINST A MODERATE HAZARD.

**HIGH HAZARD** - AN ACTUAL OR POTENTIAL THREAT OF CONTAMINATION TO THE PUBLIC WATER SYSTEM OR TO A CUSTOMER'S POTABLE WATER SYSTEM THAT COULD CAUSE SERIOUS ILLNESS OR DEATH.

**IMMINENT HAZARD** - AN ACTUAL THREAT OF CONTAMINATION TO THE PUBLIC WATER SYSTEM THAT COULD CAUSE SERIOUS ILLNESS OR DEATH.

**MODERATE HAZARD** - AN ACTUAL OR POTENTIAL THREAT OF DAMAGE TO THE PHYSICAL COMPONENTS COMPRISING THE PUBLIC WATER SYSTEM OR A CUSTOMER'S POTABLE WATER SYSTEM, OR OF POLLUTION TO THE PUBLIC WATER SYSTEM OR TO A CUSTOMER'S POTABLE WATER SYSTEM.

**POLLUTION** - THE PRESENCE OF ANY SUBSTANCE IN WATER THAT TENDS TO DEGRADE THE QUALITY OF SUCH WATER OR ADVERSELY AFFECTS THE USEFULNESS OF SUCH WATER.

**POTABLE WATER** - WATER FROM ANY SOURCE WHICH HAS BEEN APPROVED FOR HUMAN CONSUMPTION BY THE APPROPRIATE AGENCY OF THE STATE OF NORTH CAROLINA AND/OR MECKLENBURG COUNTY.

**PRIVATE WATER SYSTEM** - ANY PIPE(S), SYSTEM OF PIPES OR OTHER ASSOCIATED FACILITIES THAT IS NOT PART OF THE PUBLIC WATER SYSTEM AND IS USED IN WHOLE OR IN PART TO MOVE OR RECEIVE WATER, REGARDLESS OF THE SOURCE(S) OF THE WATER IN SUCH SYSTEM.

**PROTECTED CROSS-CONNECTION** - ANY PHYSICAL CONNECTION OR OTHER CONDITION WHICH DOES NOT PERMIT BACKFLOW BECAUSE CONTAINMENT IS ACHIEVED.

**PUBLIC WATER SYSTEM** - THE POTABLE WATER SYSTEM OWNED AND OPERATED BY THE CITY THROUGH CMUD. THIS SYSTEM INCLUDES ALL DISTRIBUTION MAINS, LINES, PIPES, CONNECTIONS, STORAGE TANKS, AND OTHER FACILITIES CONVEYING POTABLE WATER FROM THE SEVERAL WATER TREATMENT PLANTS TO THE SERVICE CONNECTION OF EACH CUSTOMER.

**REDUCED PRESSURE PRINCIPLE ASSEMBLY** - AN APPROVED, PROPERLY FUNCTIONING ASSEMBLY CONTAINING TWO, INDEPENDENTLY ACTING CHECK VALVES WITH A HYDRAULICALLY OPERATING, MECHANICALLY INDEPENDENT PRESSURE DIFFERENTIAL RELIEF VALVE LOCATED BETWEEN THE CHECK VALVES AND AT THE SAME TIME BELOW THE FIRST CHECK VALVE. THE ASSEMBLY MUST INCLUDE PROPERLY LOCATED TEST COCKS AND TIGHTLY CLOSING SHUT-OFF VALVES AT EACH END OF THE ASSEMBLY. THIS ASSEMBLY IS DESIGNED TO PROTECT AGAINST A HIGH HAZARD.

**SERVICE CONNECTION** - THE TERMINAL END OF A COMPLETE SERVICE CONNECTION, OR, IN THE ABSENCE OF A COMPLETE SERVICE CONNECTION, THE POINT AT WHICH WATER LEAVES THE PUBLIC WATER SYSTEM AND ENTERS A PRIVATE WATER SYSTEM.

**UNAPPROVED WATER SUPPLY** - A WATER SUPPLY WHICH HAS NOT BEEN APPROVED FOR HUMAN CONSUMPTION BY THE APPROPRIATE AGENCY OF THE STATE OF NORTH CAROLINA AND/OR MECKLENBURG COUNTY.

**UNPROTECTED CROSS-CONNECTION** - ANY PHYSICAL CONNECTION OR OTHER CONDITION WHICH COULD PERMIT BACKFLOW TO OCCUR BY ANY MEANS INCLUDING, BUT NOT LIMITED TO, MANIPULATION OF VALVES, IMPROPER FUNCTIONING OF VALVES, OR DIRECT DISCHARGE. UNPROTECTED CROSS-CONNECTION INCLUDES ANY CONDITION IN WHICH BACKFLOW COULD OCCUR AS A RESULT OF THE IMPROPER FUNCTIONING OF A BACKFLOW PREVENTION ASSEMBLY.

### III. INSTALLATION SPECIFICATIONS

The installation location of all backflow prevention assemblies shall be in an area that provides a safe working environment for testing and maintenance. This area shall be readily accessible, away from electrical hazards and free from dirt. The location must meet requirements of all other local authorities i.e. Fire, Planning, Zoning, City Department of Transportation (CDOT) or North Carolina Department of Transportation (NCDOT).

The installation shall be in accordance with the manufacturers information, North Carolina State Building Code Vol. II and CMUD. Installation of backflow prevention assemblies shall be upstream of the first branch line leading off the service line. If CMUD determines that it is impossible or impractical for the backflow prevention assembly to be installed outside it may be installed just inside the building. All backflow assemblies shall be installed in a horizontal direction. The backflow prevention assembly must be installed by a licensed plumbing, or utility contractor. Fire line services require a licensed fire sprinkler contractor.

The type of backflow prevention assembly installed will be determined by CMUD and shall depend upon the degree of hazard as stated in the ordinance. If the hazard cannot be determined then a reduced pressure principle assembly shall be installed. The backflow prevention assemblies installed shall be CMUD approved backflow prevention assemblies which include the shut-off valves on each end of the unit and are considered part of the unit. These shut-off valves shall be those approved with each specific unit and there shall not be any substitutions. There shall be four test cocks provided as specified in the section titled "Approved Assemblies and Materials."

1. On the upstream side of the first shut off valve (upstream being the side closest to the property line)
2. Between the first shut off valve and the first check valve.
3. Between the first and second check valve.
4. Between the second check valve and the second shut off valve.

All installations should be installed where easily accessible for testing and maintenance.

Reduced pressure principle backflow prevention assemblies (RP) shall be installed above ground outside zoning setback areas and according to CMUD standard details.

The minimum height from the relief port to the ground shall be 12" and the maximum height shall be 30". A floor drain or an air-gap drain shall be provided for RP's installed inside of buildings (minimum drain sizes are listed in these specifications). For 3/4" - 2", the clearance for an RP installed inside a building shall be 4" minimum from the wall to shut off valve, 30" minimum from the wall or any obstruction on the side utilized for testing and 6" minimum on the other to the assembly. For 3" - 10" RP, the clearance shall be 30" minimum from the wall or any obstruction on the side utilized for testing and 12" minimum on the other. RP's must be installed in an upright horizontal direction.

Double check valve assemblies (DCVA) may be installed above ground or below ground and shall be according to CMUD standard details. DCVA's must be installed in an upright horizontal direction. If the DCVA is installed below ground, it must be installed in a vault. The vault must have positive drainage, by gravity to surface of ground, or to a catch basin in a private storm drain system. If positive drainage cannot be accomplished, the DCVA shall be installed above ground outside zoning setback areas. All drainage systems shall be approved by Building Standards Plumbing Inspection.

If drainage is provided to a catch basin in a private storm drain system, the invert elevation of the drain pipe must be at or above the (top) crown level of the main storm drain line pipe flowing out of the catch basin. All work shall only be performed on the customers property and not in the public road right-of-way. Minimum drain sizes are listed in these specifications. Vault installations shall conform to CMUD Standard Details for DCVA vault installations.

If the DCVA is installed in a vault, it must be easily accessible for testing and maintenance. The length and width shall be such that the entire assembly may be removed. For 3/4" and 1" DCVA there shall be a minimum of 8" clearance on the side of the DCVA used for testing and 4" minimum on the other. For 1 1/2" and 2" DCVA there shall be a minimum of 12" clearance on the side of the DCVA used for testing and 6" minimum on the other. There shall be a minimum of 4" clearance on each end. For 3" - 10" DCVA there shall be a minimum of 30" clearance on the side of the assembly used for testing and maintenance, 12" clearance on the other, and 8" clearance on each end. DCVA's shall be installed with a minimum of 12" and a maximum of 30" clearance between the bottom surface of the body and the ground or floor. If the DCVA is installed inside a building the maximum height shall be 60". The clearance for 3/4"-2" DCVA installed inside a building shall be 4" minimum from the wall to shut off valve, 30" minimum from the wall to the assembly or obstruction on the side utilized for testing and 6" minimum on the other. For 3" - 10" DCVA, the clearance shall be 30" minimum from the wall or obstruction on the side utilized for testing and 12" minimum on the other.

The backflow prevention assembly is the responsibility of the customer to install and maintain. If damage occurs to the assembly for any reason it is the customers responsibility to repair or replace it.



It is recommended that protective structures be used to prevent freezing or vandalism for backflow prevention assemblies installed outside above ground. The backflow prevention assembly shall be protected from freezing in accordance with current State Plumbing Code. The backflow prevention assembly must be readily accessible for maintenance and testing including removing the entire assembly. Adequate drainage shall be provided by hinged door or drain ports along the bottom of the walls of the protective structure. The minimum drain size shall be provided according to current state plumbing code. Insulation shall not be wrapped around the assembly.

If the structure is non-removable and must be entered in order to test or repair the assembly, the same minimum and maximum clearance that is specified for vault installations shall apply.

Covers or doors placed above a protective structure or vault shall be lightweight and shall have adequate width and length to remove the entire assembly. Doors or covers for 3" - 10" vault installations shall be double hinged.

Fire line installations shall be as follows: High hazard fire line installations require a reduced pressure principle assembly (RP) as stated in the ordinance. Moderate hazard fire line installations require a double check valve assembly. It is recommended, if possible, if a booster pump exists, that it be approximately 100-feet downstream of the backflow prevention assembly. **Strainers shall not be installed on fire lines. All fire line installations shall be protected to a min. of 40 degrees or as required by current building code.**

Fire line services with only one fire hydrant with a maximum of distance of 100-feet from the property line shall not require backflow prevention. All assemblies on a fire line, or combination domestic and fire, shall be fire line approved installations with OS & Y type shut-off valves. These valves shall be provided with supervisory tamper switches as required by current Building Code enforced by the Fire Marshal.

Residential lawn irrigation service installations shall be as follows:

The backflow prevention assembly must be installed on the irrigation service line before any branching of the private system and in accordance with all other CMUD Installation Guidelines and Standard Details for Backflow Prevention Assemblies. The assembly may be installed adjacent to the house and shall be outside the footprint of the house.

All residential lawn irrigation system services tapped from the residential domestic service shall require a backflow prevention assembly on the irrigation service line before any branching of the irrigation system and in accordance with CMUD Installation Guidelines and Standard Details for Backflow Assemblies.

Once installation is completed, the customer shall have the backflow prevention assembly inspected by Building Standards Plumbing Inspection or a CMUD representative and tested by a CMUD approved certified tester. The test results shall be submitted to CMUD for the initial test and annual tests thereafter. All rubber parts shall be replaced every five (5) years.

## INSTALLATION REFERENCE TABLES

### MIN. DRAIN SIZES FOR VAULT INSTALLATIONS (DOUBLE CHECK VALVE ONLY)

<u>Size of Assembly</u>	<u>Drain Size</u>
3/4" - 2"	2"
2 1/2" - 10"	4"

### MINIMUM DRAIN SIZES REQUIRED FOR RP INDOOR INSTALLATION

<u>Size of Assembly</u>	<u>Drain Size</u>
3/4" - 1"	4"
1 1/2" - 2"	5"
2 1/2" - 3"	6"
4" - 6"	8"
8" - 10"	2 - 8"

### OVERALL DIMENSIONS OF ASSEMBLIES INCLUDING CMUD CLEARANCES FOR VAULT INSTALLATIONS (INSIDE DIMENSIONS)

<u>SIZE</u>	<u>LENGTH</u>	<u>DOMESTIC INSTALLATIONS</u>		<u>FIRE LINE INSTALLATIONS</u>		<u>HEIGHT</u>
		<u>WIDTH</u>	<u>HEIGHT</u>	<u>LENGTH</u>	<u>WIDTH</u>	
3/4"	23 3/4"	20 1/4"	34 1/2"			
1"	26"	20 1/4"	34 3/4"			
1 1/2"	36 5/8"	30 1/2"	37"			
2"	39 1/2"	30 1/2"	37"			
2 1/2"	55"	52 1/2"	35"			
3"	57"	54"	36"			
4"	68"	55 1/2"	41"	68"	55 1/2"	47 11/16"
6"	79"	60 1/2"	49 3/4"	79"	60 1/2"	56 1/2"
8"	91 1/2"	62 1/4"	63 1/4"	91 1/2"	62 1/2"	66 1/2"
10"	106"	64 3/4"	56 1/4"	106"	64 3/4"	75 3/4"

\*\* LENGTHS DO NOT INCLUDE STRAINER \*\*

\*\* NO STRAINERS ALLOWED ON FIRE LINES \*\*

<u>SIZE</u>	<u>LENGTH</u>
2 1/2"	9 3/4"
3"	10"
4"	12"
6"	18 7/8"
8"	21 3/8"
10"	26"

DIMENSIONS LISTED ON THIS SHEET ARE APPROXIMATE DIMENSIONS OF ASSEMBLIES THAT ARE LISTED ON CMUD APPROVED LIST ! REFER TO MANUFACTURER INFORMATION FOR SPECIFIC ASSEMBLY DIMENSIONS.

#### IV. CONSTRUCTION GUIDELINES

##### EXISTING RESIDENTIAL SERVICE WITH NEW LAWN IRRIGATION SYSTEM TIED TO EXISTING SERVICE LINE:

##### I-REQUIREMENTS FOR BACKFLOW PREVENTION ASSEMBLY INSTALLATION

- A. INSTALL ASSEMBLY BEFORE ANY BRANCHES IN NEW IRRIGATION SYSTEM OUTSIDE ZONING SETBACK AREAS, PER CMUD STANDARD DETAILS.
- B. LOCATE 12" ABOVE GROUND MIN. 30" MAX. IN HORIZONTAL DIRECTION. 30" MIN. CLEAR OF ANY PERMANENT OBSTRUCTION. SEE INSTALLATION SPECIFICATIONS FOR BELOW GROUND REQUIREMENTS.
- C. USE TYPE "L", or "K" COPPER OR GALVANIZED STEEL PIPE (1" DIA. MIN.), FROM 5' BEFORE TO 5' PAST ASSEMBLY.
- D. PROTECTIVE STRUCTURE REQUIRED WITH INSULATED PROTECTION 7.4R FACTOR MINIMUM. INSULATION SHALL NOT BE WRAPPED AROUND ASSEMBLY.
- E. LOCATION OF CONNECTION AND BACKFLOW PREVENTION ASSEMBLY WILL BE LOCATED OUTSIDE AND ACCESSIBLE TO CMUD AT ALL TIMES.
- F. IF UNIONS ARE USED, CAPS MUST BE PROVIDED AND STORED WITH ASSEMBLY, FOR USE ANY TIME THE ASSEMBLY IS REMOVED. IT IS REQUIRED TO CAP REMAINING PIPING TO SERVICE LINE AND IS SUBJECT TO CMUD INSPECTION AT ANY TIME ASSEMBLY IS REMOVED.
- G. ASSEMBLY REQUIRED TO BE INSTALLED BY A NC STATE LICENSED PLUMBER OR NC STATE LICENSED UTILITY CONTRACTOR.

##### II-PROCEDURES FOR APPROVAL OF INSTALLATION

- A. APPLY FOR PLUMBING PERMIT AT BUILDING STANDARDS.
  - 1) APPLY FOR PLUMBING PERMIT AT BLDG. STD.. TURN IN COMPLETED BACKFLOW QUESTIONNAIRE WITH PLUMBING PERMIT APPLICATION TO BUILDING STANDARDS. BUILDING STANDARDS WILL FORWARD QUESTIONNAIRE TO CMUD SYSTEMS AND RECORDS.
  - 2) FOR QUICK DETERMINATION OF ASSEMBLY REQUIREMENTS DELIVER QUESTIONNAIRE TO CMUD SYSTEMS AND RECORDS.
  - 3) WITH QUESTIONNAIRE CMUD WILL SPECIFY ASSEMBLY REQUIRED (R.P. OR D.C.V.A.). CMUD WILL NOTIFY OWNER LISTED ON QUESTIONNAIRE AND BLDG. STD. OF REQUIREMENTS.

- B. INSTALL IRRIGATION SYSTEM
- C. CONTACT BLDG. STD. TO INSPECT INSTALLATION.
- D. WITH APPROVED INSTALLATION CMUD REQUIRES OWNER TO SUBMIT A COPY OF THE BACKFLOW PREVENTION ASSEMBLY TEST RECORD. SEE TESTING REQUIREMENTS.

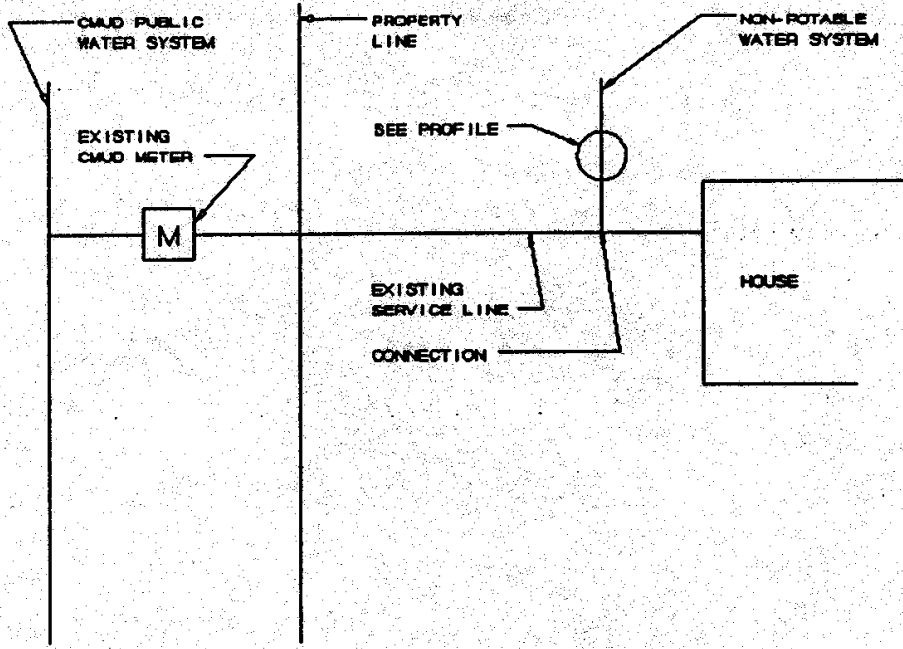

PLAN VIEW

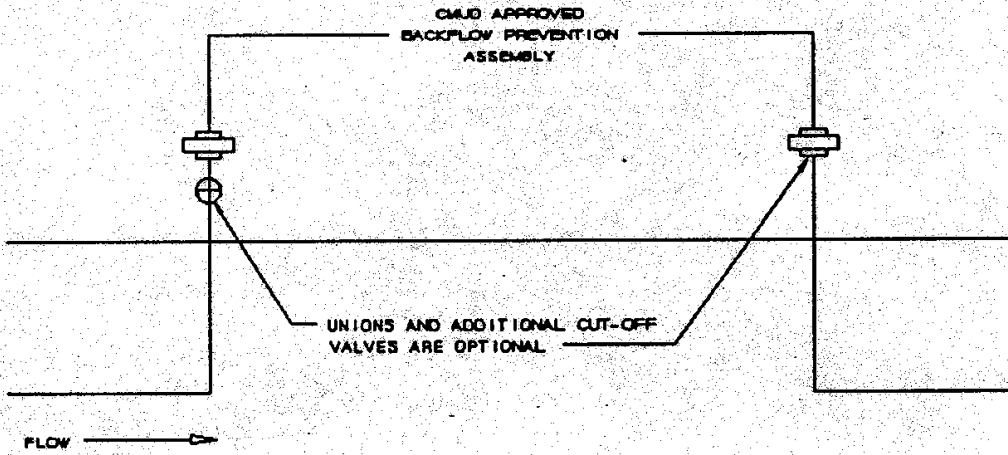

PROFILE VIEW

EXISTING RESIDENTIAL SERVICE  
 W/ NEW LAWN IRRIGATION SYSTEM  
 TIED TO EXISTING SERVICE LINE

NEW RESIDENTIAL LAWN IRRIGATION SERVICE  
WITH NEW LAWN IRRIGATION SYSTEM TIED TO NEW LAWN METER:

I-REQUIREMENTS FOR BACKFLOW PREVENTION ASSEMBLY INSTALLATION

- A. INSTALL ASSEMBLY BEFORE ANY BRANCHES IN NEW IRRIGATION SYSTEM OUTSIDE ZONING SET BACK AREAS, PER CMUD STANDARD DETAILS.
- B. LOCATE 12" ABOVE GROUND MIN. 30" MAX. IN HORIZONTAL DIRECTION. 30" MIN. CLEAR OF ANY PERMANENT OBSTRUCTION. SEE INSTALLATION SPECIFICATIONS FOR BELOW GROUND REQUIREMENTS.
- C. USE TYPE "L", or "K" COPPER OR GALVANIZED STEEL PIPE (1" DIA. MIN.), FROM 5' BEFORE TO 5' PAST ASSEMBLY.
- D. PROTECTIVE STRUCTURE REQUIRED WITH INSULATED PROTECTION 7.4R FACTOR MINIMUM. INSULATION SHALL NOT BE WRAPPED AROUND ASSEMBLY.
- E. LOCATION OF CONNECTION AND BACKFLOW PREVENTION ASSEMBLY WILL BE LOCATED OUTSIDE AND ACCESSIBLE TO CMUD AT ALL TIMES.
- F. IF UNIONS ARE USED, CAPS MUST BE PROVIDED AND STORED WITH ASSEMBLY, FOR USE ANY TIME THE ASSEMBLY IS REMOVED. IT IS REQUIRED TO CAP REMAINING PIPING TO SERVICE LINE AND IS SUBJECT TO CMUD INSPECTION AT ANY TIME ASSEMBLY IS REMOVED.
- G. ASSEMBLY IS REQUIRED TO BE INSTALLED BY A NC STATE LICENSED PLUMBER OR NC STATE LICENSED UTILITY CONTRACTOR.

II-PROCEDURES FOR APPROVAL OF INSTALLATION

- A. APPLY FOR NEW LAWN METER AT CMUD.
  - 1) COMPLETE BACKFLOW QUESTIONNAIRE.
  - 2) TURN IN COMPLETED BACKFLOW QUESTIONNAIRE WITH MONEY FOR SERVICE CONNECTION FEES, TO CMUD.
  - 3) WITH QUESTIONNAIRE CMUD WILL DETERMINE HAZARD AND SPECIFY ASSEMBLY REQUIRED (R.P. OR D.C.V.A.). CMUD WILL NOTIFY OWNER LISTED ON QUESTIONNAIRE AND BLDG. STD. OF REQUIREMENTS.
- B. APPLY FOR PLUMBING PERMIT AT BLDG. STD.
- C. FLAG LOCATION FOR CMUD CREW TO INSTALL NEW METER.
- D. INSTALL IRRIGATION SYSTEM.
- E. CONTACT BLDG. STD. TO INSPECT INSTALLATION.
- F. WITH APPROVED INSTALLATION CMUD REQUIRES OWNER TO SUBMIT A COPY OF THE BACKFLOW PREVENTION ASSEMBLY TEST RECORD. SEE TESTING REQUIREMENTS.

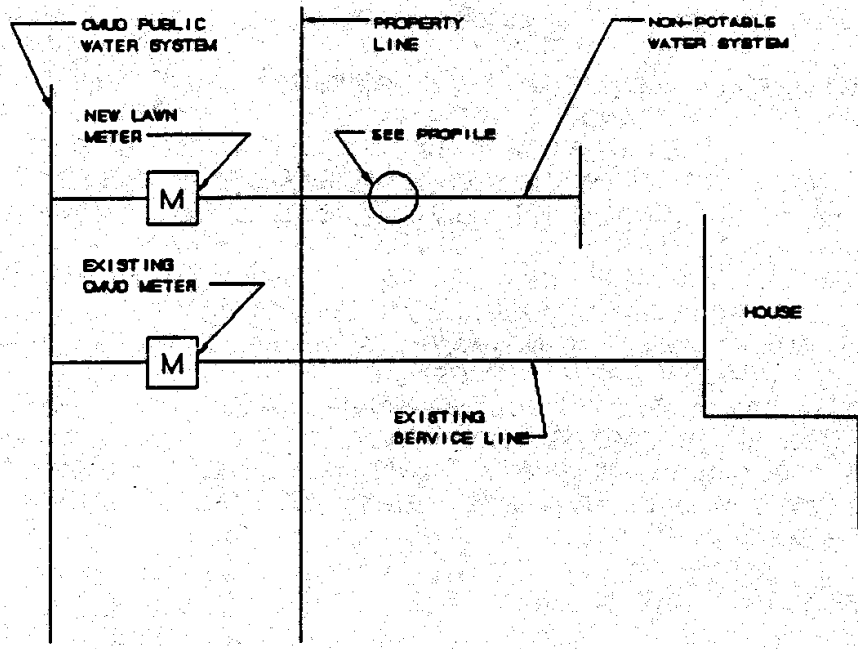

PLAN VIEW

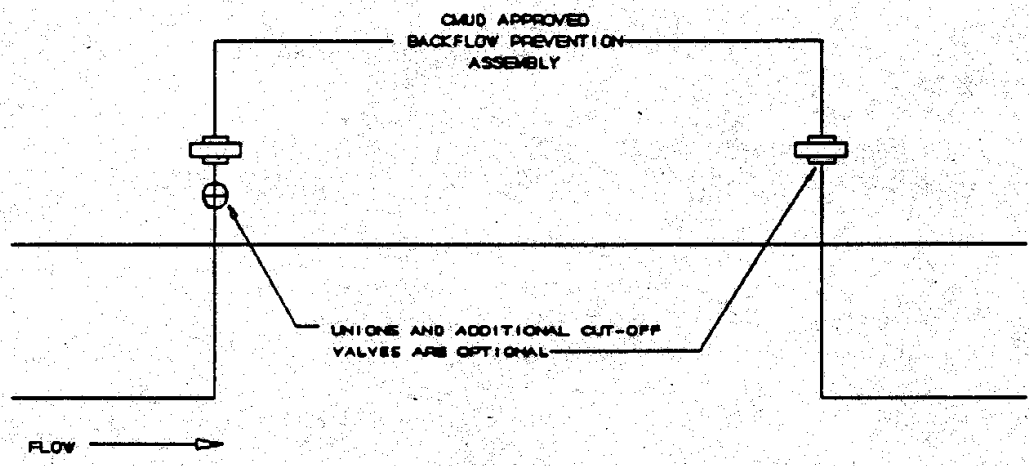

PROFILE VIEW

**NEW RESIDENTIAL LAWN  
IRRIGATION SYSTEM**



EXISTING COMMERCIAL SERVICE

WITH LAWN IRRIGATION OR FIRE SYSTEM TIED TO EXISTING SERVICE LINE:

I-1. CMUD REQUIREMENTS AT EXISTING METER

- A. INSTALL ASSEMBLY BEFORE ANY BRANCHES IN NEW SYSTEM OUTSIDE ZONING SETBACK AREAS, PER CMUD STANDARD DETAILS OUTSIDE AND ACCESSIBLE TO CMUD AT ALL TIMES. **ON FIRE LINES SHUT-OFF VALVES MUST BE OS&Y TYPE, AND BE PROVIDED WITH SUPERVISORY TAMPER SWITCHES WITH TROUBLE SIGNAL TO GO TO THE EMERGENCY CONTROL STATION AS REQUIRED BY CURRENT BUILDING CODE.**
- B. LOCATE 12" ABOVE GROUND MIN. 30" MAX. IN HORIZONTAL DIRECTION. 30" MIN. CLEAR OF ANY PERMANENT OBSTRUCTION. **STRAINERS SHALL NOT BE INSTALLED ON FIRE SYSTEMS.** SEE INSTALLATION SPECIFICATIONS FOR BELOW GROUND REQUIREMENTS.
- C. USE TYPE "L", or "K" COPPER, D.I.P. (3"-10"), OR GALVANIZED STEEL PIPE (1" DIA. MIN.), FROM 5' BEFORE TO 5' PAST ASSEMBLY.
- D. PROTECTIVE STRUCTURE REQUIRED WITH INSULATED PROTECTION 7.4R FACTOR MINIMUM. INSULATION SHALL NOT BE WRAPPED AROUND ASSEMBLY. **ALL ASSEMBLIES USED ON FIRE LINE SERVICES SHALL BE PROTECTED TO MIN. 40 DEGREES OR AS REQUIRED BY CURRENT BUILDING CODE.**
- E. IF UNIONS ARE USED (3/4"-2"), CAPS MUST BE PROVIDED AND STORED WITH ASSEMBLY, FOR USE ANY TIME THE ASSEMBLY IS REMOVED. IT IS REQUIRED TO CAP REMAINING PIPING TO SERVICE LINE AND IS SUBJECT TO CMUD INSPECTION AT ANY TIME ASSEMBLY IS REMOVED.
- F. ASSEMBLY REQUIRED TO BE INSTALLED BY A NC STATE LICENSED PLUMBER, UTILITY CONTRACTOR, OR NC STATE LICENSED FIRE SPRINKLER CONTRACTOR.

2. BUILDING STANDARDS REQUIREMENTS FOR BACKFLOW ASSEMBLY AT CONNECTION OF NEW LAWN IRRIGATION OR FIRE SYSTEM

- A. LOCATE 12" ABOVE GROUND MIN. 30" MAX. BEFORE ANY BRANCHES IN NEW SYSTEM, IN HORIZONTAL DIRECTION. 30" MIN. FROM ANY OBSTRUCTION.
- B. PROTECTIVE STRUCTURE REQUIRED WITH INSULATED PROTECTION 7.4R FACTOR MINIMUM. INSULATION SHALL NOT BE WRAPPED AROUND ASSEMBLY. **ALL ASSEMBLIES USED ON FIRE LINE SERVICES SHALL BE PROTECTED TO MIN. 40 DEGREES OR AS REQUIRED BY CURRENT BUILDING CODE.**
- C. IF UNIONS ARE USED (3/4"-2"), CAPS MUST BE PROVIDED AND STORED WITH ASSEMBLY, FOR USE ANY TIME THE ASSEMBLY IS REMOVED.
- D. ASSEMBLY REQUIRED TO BE INSTALLED BY A NC STATE LICENSED PLUMBER, UTILITY CONTRACTOR, OR NC STATE LICENSED FIRE SPRINKLER CONTRACTOR.

II-PROCEDURES FOR APPROVAL OF INSTALLATION AT EXISTING METER

- A. APPLY FOR PLUMBING PERMIT AT BUILDING STANDARDS.
  - 1) COMPLETE APPLICATION FOR PLUMBING PERMIT AND PAY FEE.
  - 2) TURN IN COMPLETED BACKFLOW QUESTIONNAIRE WITH PLUMBING PERMIT APPLICATION TO BUILDING STANDARDS. BUILDING STANDARDS WILL FORWARD QUESTIONNAIRE TO CMUD.
  - 3) FOR QUICK DETERMINATION OF HAZARD AND ASSEMBLY REQUIREMENTS DELIVER QUESTIONNAIRE TO CMUD SYSTEMS AND RECORDS.
  - 4) CMUD WILL DETERMINE HAZARD AND SPECIFY ASSEMBLY REQUIRED. CMUD WILL NOTIFY OWNER AND BLDG. STD. OF REQUIREMENTS.
- B. INSTALLATION OF ASSEMBLY MAY BE SUBJECT TO OTHER LOCAL AUTHORITY REQUIREMENTS AND APPROVAL (i.e. FIRE, PLANNING, ZONING, OR DOT).
- C. INSTALL IRRIGATION OR FIRE SYSTEM AND BACKFLOW PREVENTION ASSEMBLIES AT METER AND AT CONNECTION OF NEW SYSTEM.
- D. CONTACT BUILDING STANDARDS TO INSPECT INSTALLATIONS.
- E. WITH APPROVED INSTALLATION CMUD REQUIRES OWNER TO SUBMIT A COPY OF THE BACKFLOW PREVENTION ASSEMBLY TEST RECORD AT EXISTING METER. SEE TESTING REQUIREMENTS.

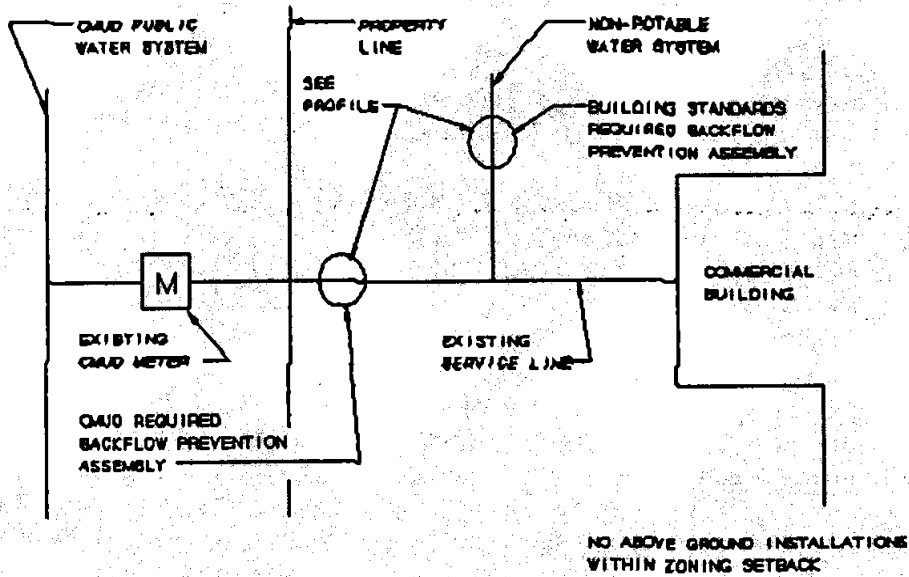

PLAN VIEW

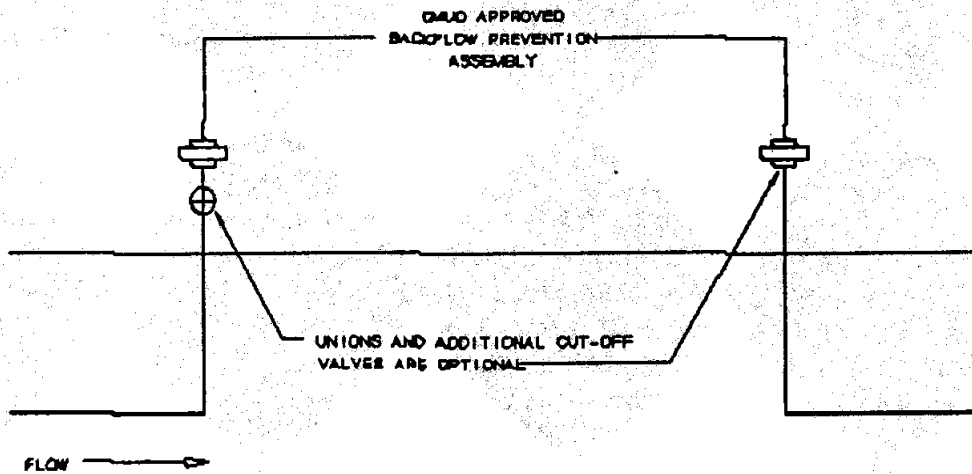

PROFILE VIEW

EXISTING COMMERCIAL SERVICE  
W/ NEW IRRIGATION OR FIRE  
SYSTEM CONNECTION

NEW COMMERCIAL, LAWN IRRIGATION, OR FIRE LINE SERVICE  
WITH NEW SERVICE, LAWN, OR FIRE SYSTEM TIED TO NEW METER:

I-1. REQUIREMENTS FOR BACKFLOW PREVENTION ASSEMBLY INSTALLATION

- A. INSTALL ASSEMBLY BEFORE ANY BRANCHES IN NEW SYSTEM OUTSIDE ZONING SETBACK AREAS, PER CMUD STANDARD DETAILS. **ON FIRE LINES SHUT-OFF VALVES SHALL BE OS&Y TYPE, AND BE PROVIDED WITH SUPERVISORY TAMPER SWITCHES WITH TROUBLE SIGNAL TO GO TO THE EMERGENCY CONTROL STATION AS REQUIRED BY CURRENT BUILDING CODE.**
- B. LOCATE 12" ABOVE GROUND MIN. 30" MAX. IN HORIZONTAL DIRECTION. 30" MIN. CLEAR OF ANY PERMANENT OBSTRUCTION. **NO STRAINERS SHALL BE INSTALLED ON FIRE SYSTEMS.** SEE INSTALLATION SPECIFICATIONS FOR BELOW GROUND REQUIREMENTS.
- C. USE TYPE "L", or "K" COPPER, D.I.P. (3"-10") OR GALVANIZED STEEL PIPE (1" DIA. MIN.), FROM 5' BEFORE TO 5' PAST ASSEMBLY.
- D. PROTECTIVE STRUCTURE REQUIRED WITH INSULATED PROTECTION 7.4R FACTOR MINIMUM. INSULATION SHALL NOT BE WRAPPED AROUND ASSEMBLY. **ALL ASSEMBLIES USED ON FIRE LINE SERVICES SHALL BE PROTECTED TO MIN. 40 DEGREES OR AS REQUIRED BY CURRENT BUILDING CODE.**
- E. LOCATION OF CONNECTION AND BACKFLOW PREVENTION ASSEMBLY WILL BE LOCATED OUTSIDE AND ACCESSIBLE TO CMUD AT ALL TIMES.
- F. IF UNIONS ARE USED (3/4"-2"), CAPS MUST BE PROVIDED AND STORED WITH ASSEMBLY, FOR USE ANY TIME THE ASSEMBLY IS REMOVED. IT IS REQUIRED TO CAP REMAINING PIPING TO SERVICE LINE AND IS SUBJECT TO CMUD INSPECTION AT ANY TIME ASSEMBLY IS REMOVED.
- G. ASSEMBLY REQUIRED TO BE INSTALLED BY A NC STATE LICENSED PLUMBER, UTILITY CONTRACTOR, OR NC STATE LICENSED FIRE SPRINKLER CONTRACTOR.

2. BUILDING STANDARDS REQUIREMENTS FOR BACKFLOW ASSEMBLY AT CONNECTION OF NEW LAWN IRRIGATION OR FIRE SYSTEM

- A. LOCATE 12" ABOVE GROUND MIN. 30" MAX. BEFORE ANY BRANCHES IN NEW SYSTEM, IN HORIZONTAL DIRECTION. 30" MIN. FROM ANY OBSTRUCTION.
- B. PROTECTIVE STRUCTURE REQUIRED WITH INSULATED PROTECTION 7.4R FACTOR MINIMUM. INSULATION SHALL NOT BE WRAPPED AROUND ASSEMBLY. **ALL ASSEMBLIES USED ON FIRE LINE SERVICES SHALL BE PROTECTED TO MIN. 40 DEGREES OR AS REQUIRED BY CURRENT BUILDING CODE.**
- C. IF UNIONS ARE USED (3/4"-2"), CAPS MUST BE PROVIDED AND STORED WITH ASSEMBLY, FOR USE ANY TIME THE ASSEMBLY IS REMOVED.
- D. ASSEMBLY REQUIRED TO BE INSTALLED BY A NC STATE LICENSED PLUMBER, UTILITY CONTRACTOR, OR NC STATE LICENSED FIRE SPRINKLER CONTRACTOR.

II-PROCEDURES FOR APPROVAL OF INSTALLATION

- A. APPLY FOR PLUMBING PERMIT AT BUILDING STANDARDS.
  - 1) COMPLETE APPLICATION FOR PLUMBING PERMIT AND PAY FEE.
  - 2) TURN IN COMPLETED BACKFLOW QUESTIONNAIRE WITH PLUMBING PERMIT APPLICATION TO BUILDING STANDARDS. BUILDING STANDARDS WILL FORWARD QUESTIONNAIRE TO CMUD.
  - 3) FOR QUICK DETERMINATION OF HAZARD AND ASSEMBLY REQUIREMENTS DELIVER QUESTIONNAIRE TO CMUD SYSTEMS AND RECORDS.
  - 4) CMUD WILL DETERMINE HAZARD AND SPECIFY ASSEMBLY REQUIRED.
- B. INSTALLATION OF ASSEMBLY MAY BE SUBJECT TO OTHER LOCAL AUTHORITY REQUIREMENTS AND APPROVAL (i. e. FIRE, ZONING, PLANNING, OR DOT).
- C. APPLY FOR NEW METER AT CMUD.
  - 1) TURN IN COPY OF COMPLETED BACKFLOW QUESTIONNAIRE WITH MONEY FOR SERVICE CONNECTION FEES.
  - 2) WITH QUESTIONNAIRE CMUD WILL DETERMINE HAZARD AND SPECIFY ASSEMBLY REQUIRED (R.P. OR D.C.V.A.). CMUD WILL NOTIFY OWNER LISTED ON QUESTIONNAIRE AND BLDG. STD. OF REQUIREMENTS.
- D. FLAG LOCATION FOR CMUD CREW TO INSTALL NEW METER.
- E. INSTALL IRRIGATION OR FIRE SYSTEM.
- F. CONTACT BLDG. STD. TO INSPECT INSTALLATION.
- G. WITH APPROVED INSTALLATION CMUD REQUIRES OWNER TO SUBMIT A COPY OF THE BACKFLOW PREVENTION ASSEMBLY TEST RECORD. SEE TESTING REQUIREMENTS.

COMBINATION METER

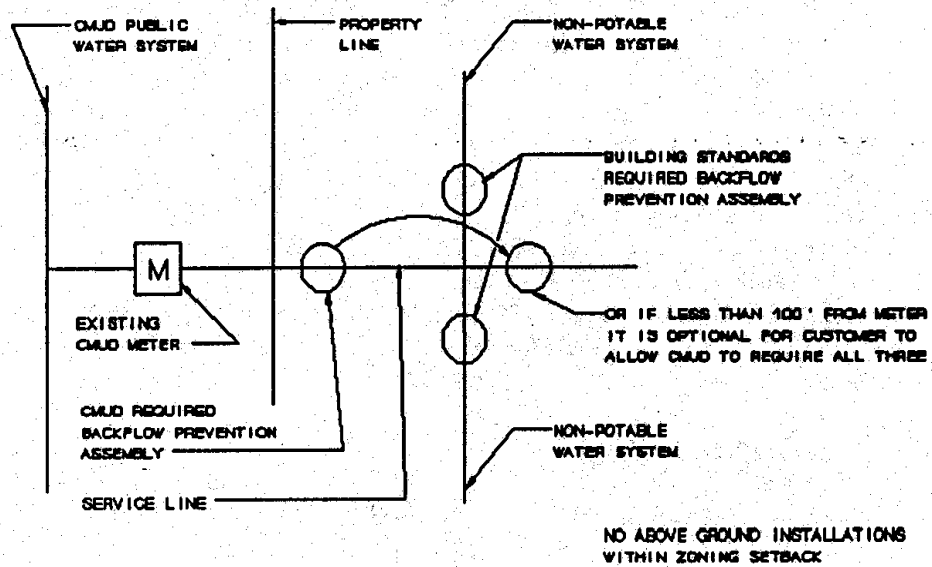

SEPARATE METERS

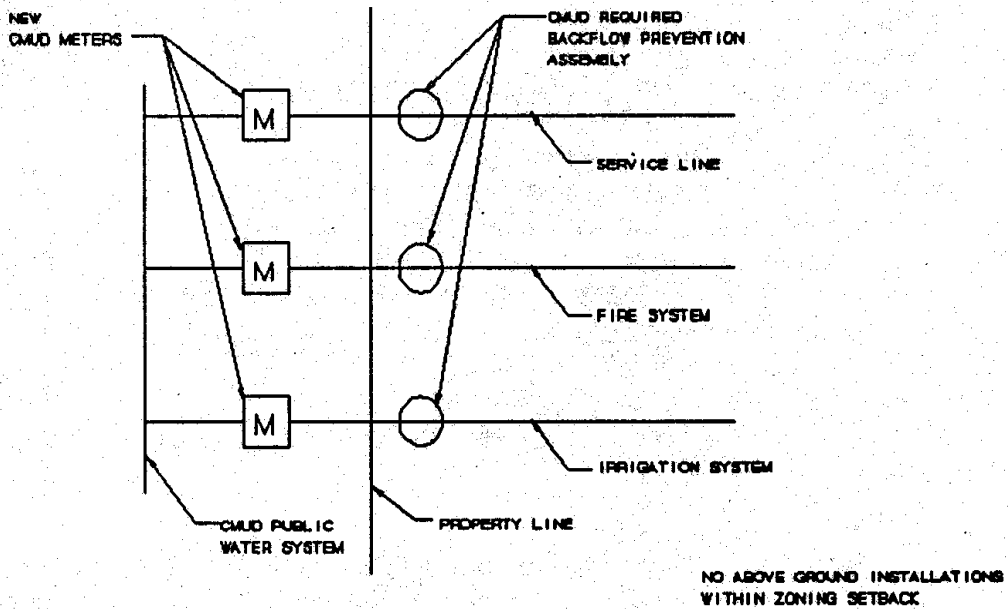

NEW COMMERCIAL SERVICE  
W/ NEW IRRIGATION OR FIRE  
SYSTEM CONNECTION

DEVELOPER INSTALLED SERVICE  
TIED TO NEW DEVELOPER INSTALLED METER

I-1. REQUIREMENTS FOR BACKFLOW PREVENTION ASSEMBLY INSTALLATION ON CUSTOMER PROPERTY FOR PRIVATE SYSTEM

- A. INSTALLATIONS MUST BE INSTALLED OUTSIDE THE PUBLIC ROAD RIGHT-OF-WAY, AND OUTSIDE ZONING SETBACK AREAS ON CUSTOMER PROPERTY.
- B. INSTALL ASSEMBLY BEFORE ANY BRANCHES IN NEW SERVICE, PER CMUD STANDARD DETAILS. **ON FIRE LINES SHUT-OFF VALVES SHALL BE OS & Y TYPE, AND BE PROVIDED WITH SUPERVISORY TAMPER SWITCHES WITH TROUBLE SIGNAL TO GO TO THE EMERGENCY CONTROL STATION AS REQUIRED BY CURRENT BUILDING CODE.**
- C. LOCATE 12" ABOVE GROUND MIN. 30" MAX. IN HORIZONTAL DIRECTION. 30" MIN. CLEAR OF ANY PERMANENT OBSTRUCTION. NO MORE THAN 100' UPSTREAM OF NEW METER. **NO STRAINERS SHALL BE INSTALLED ON FIRE SYSTEMS.** SEE INSTALLATION SPECIFICATIONS FOR BELOW GROUND REQUIREMENTS.
- D. USE TYPE "K" COPPER, D.I.P.(3"-10") OR GALVANIZED STEEL (1" DIA. MIN.) PIPE FROM 5' BEFORE TO 5' PAST ASSEMBLY.
- E. PROTECTIVE STRUCTURE REQUIRED WITH INSULATED PROTECTION 7.4R FACTOR MINIMUM. INSULATION SHALL NOT BE WRAPPED AROUND ASSEMBLY.
- F. ALL INSTALLATIONS ARE REQUIRED TO BE OUTSIDE OF SITE DISTANCE TRIANGLE.
- G. ASSEMBLY REQUIRED TO BE INSTALLED BY A NC STATE LICENSED PLUMBER OR NC STATE LICENSED UTILITY CONTRACTOR.

2. REQUIREMENTS FOR BACKFLOW PREVENTION ASSEMBLY INSTALLATION WITHIN PUBLIC ROAD RIGHT-OF-WAY (EXISTING OR FUTURE) FOR ROADWAY IRRIGATION SYSTEMS

- A. ALL CONSTRUCTION ACTIVITIES, AND MATERIALS IN AN EXISTING OR FUTURE PUBLIC ROAD RIGHT-OF-WAY SHALL COMPLY WITH THE CURRENT NCDOT POLICIES AND PROCEDURES FOR ACCOMMODATING UTILITIES ON HIGHWAY RIGHTS OF WAY, OR CDOT POLICIES AND PROCEDURES AND ANY ADDITIONAL REQUIREMENTS OF ACTIVE ENCROACHMENT AGREEMENTS.
- B. NO BACKFLOW PREVENTION ASSEMBLY SHALL BE INSTALLED IN ANY FULLY CONTROLLED OR LIMITED CONTROLLED ACCESS ROADS.
- C. NO BACKFLOW PREVENTION ASSEMBLY SHALL BE INSTALLED ABOVE GROUND IN A PUBLIC ROAD RIGHT-OF-WAY. NOTE ALL REDUCED PRESSURE PRINCIPLE BACKFLOW PREVENTION ASSEMBLY ARE REQUIRED TO BE INSTALLED ABOVE GROUND OUTSIDE OF THE PUBLIC ROAD RIGHT-OF-WAY, AND OUTSIDE ZONING SETBACK AREAS ON CUSTOMER PROPERTY.
- D. A DOUBLE CHECK VALVE ASSEMBLY SHALL BE ALLOWED TO BE INSTALLED BELOW GROUND IN A NCDOT APPROVED VAULT. ANY BELOW GROUND INSTALLATION CONFINE WITHIN THE PUBLIC ROAD RIGHT-OF-WAY SHALL BE LOCATED AS NEAR TO RIGHT-OF-WAY LINE AS POSSIBLE. OUTSIDE FACE OF VAULT MUST BE LOCATED NO MORE THAN ONE FOOT INSIDE PUBLIC RIGHT-OF-WAY. VAULT INSTALLATION ARE REQUIRED TO DRAIN TO FREE ATMOSPHERE. NOTE IF DRAINAGE CANNOT BE ACHIEVED, THE DOUBLE CHECK VALVE MUST BE PLACED ABOVE GROUND OUTSIDE THE PUBLIC ROAD RIGHT-OF-WAY, OUTSIDE ZONING SETBACK AREAS ON CUSTOMERS PROPERTY.
- E. ALL CONSTRUCTION SHALL CONFORM TO THE REQUIREMENTS FOR WATER MAIN CONSTRUCTION WITHIN THE JURISDICTION OF THE CHARLOTTE MECKLENBURG UTILITY DEPARTMENT, FROM THE METER TO AND 5 FEET BEYOND THE BACKFLOW PREVENTION ASSEMBLY INSTALLATION.
- F. ASSEMBLY REQUIRED TO BE INSTALLED BY A NC STATE LICENSED PLUMBER OR NC STATE LICENSED UTILITY CONTRACTOR.

II-PROCEDURES FOR APPROVAL OF INSTALLATION

- A. APPLY FOR NEW LAWN METER AT CMUD.
  - 1) COMPLETE BACKFLOW QUESTIONNAIRE.
  - 2) TURN IN COMPLETED BACKFLOW QUESTIONNAIRE WITH MONEY FOR SERVICE CONNECTION FEES.
  - 3) WITH QUESTIONNAIRE CMUD WILL DETERMINE HAZARD AND SPECIFY ASSEMBLY REQUIRED (R.P. OR D.C.V.A.). CMUD WILL NOTIFY OWNER LISTED ON QUESTIONNAIRE AND SUBDIVISION INSPECTION OF REQUIREMENTS.
- B. ANY INSTALLATION INSTALLED IN (EXISTING, OR FUTURE) PUBLIC ROAD RIGHT-OF-WAY, OR SET-BACK AREAS CONTROLLED BY LOCAL AUTHORITIES ARE SUBJECT TO ALL STATE AND LOCAL APPROVALS.
- C. METER WILL NOT BE ACTIVATED UNTIL ALL REQUIREMENTS OF CMUD HAVE BEEN MET SATISFACTORILY.
- D. WITH APPROVED INSTALLATION CMUD REQUIRES OWNER TO SUBMIT A COPY OF THE BACKFLOW PREVENTION ASSEMBLY TEST RECORD. SEE TESTING REQUIREMENTS.

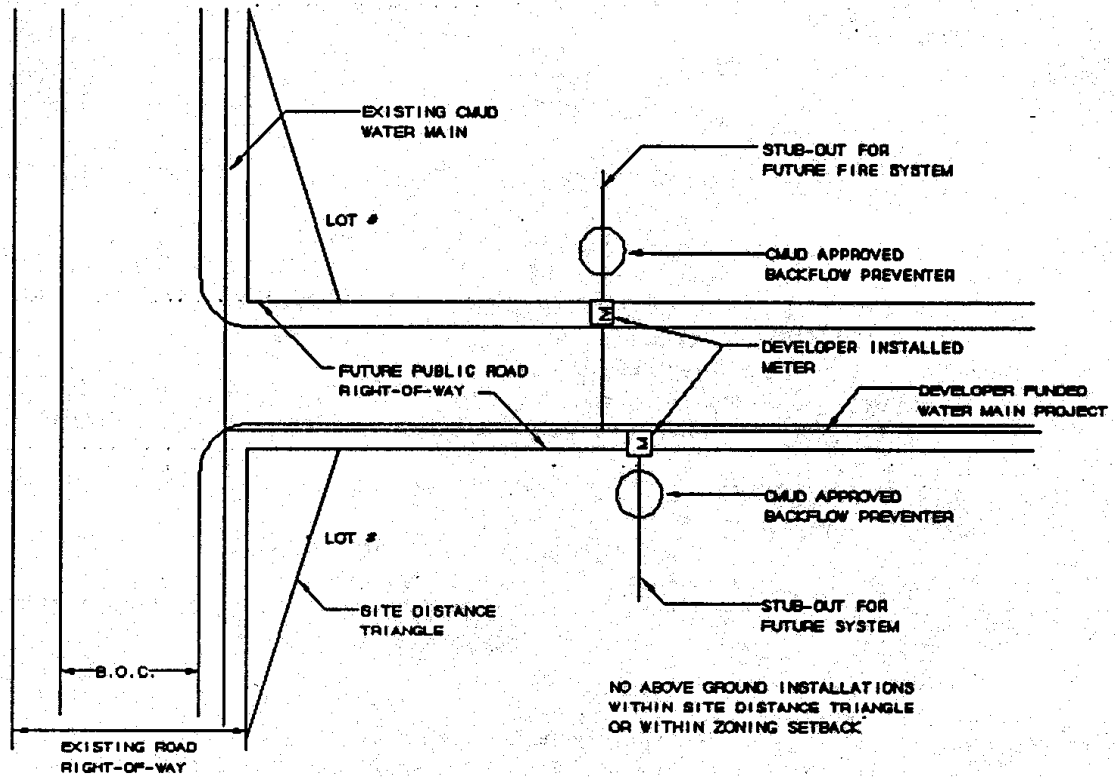

SERVICE CONNECTION  
FOR FUTURE USE

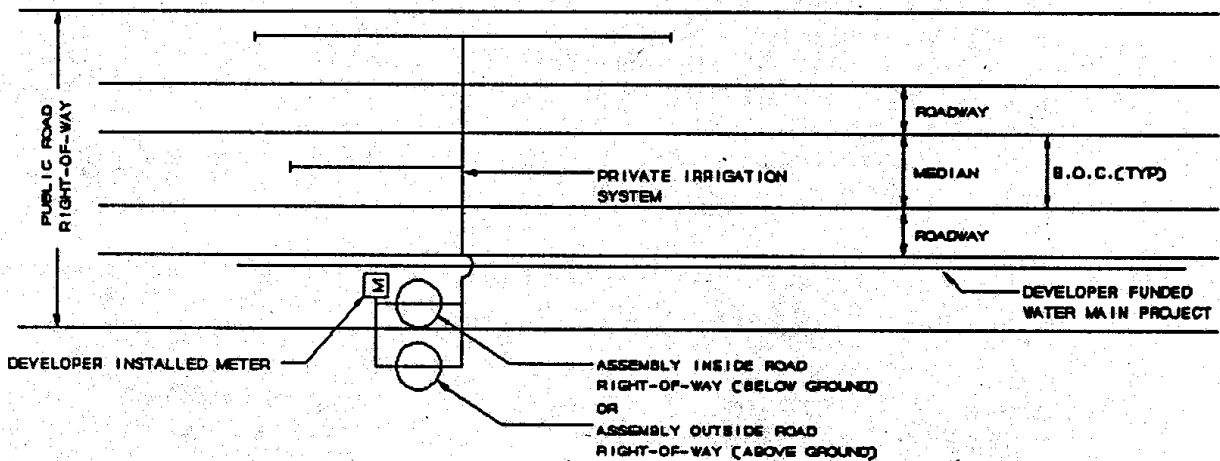

NO ABOVE GROUND INSTALLATIONS WITHIN SITE DISTANCE TRIANGLE OR WITHIN ZONING SETBACK

IRRIGATION SYSTEM IN  
PUBLIC ROAD RIGHT-OF-WAY

DEVELOPER INSTALLED  
SERVICE CONNECTION

## NEW OR EXISTING IRRIGATION SERVICE FOR A PUBLIC ROADWAY

### I-1. REQUIREMENTS FOR BACKFLOW PREVENTION ASSEMBLY INSTALLATION OUTSIDE OF PUBLIC ROAD RIGHT-OF-WAY

- A. ANY ABOVE GROUND INSTALLATIONS MUST BE INSTALLED OUTSIDE THE PUBLIC ROAD RIGHT-OF-WAY, AND OUTSIDE ZONING SETBACK AREAS ON PRIVATE PROPERTY. ALL INSTALLATIONS ARE REQUIRED TO BE LOCATED OUTSIDE AREA OF SITE DISTANCE TRIANGLE. ANY WORK IN AN EXISTING PUBLIC ROAD RIGHT-OF-WAY(R/W) REQUIRES AN ENCROACHMENT AGREEMENT WITH OWNER OF R/W.
- B. THE ASSEMBLY MUST BE INSTALLED BEFORE ANY BRANCHES IN NEW SYSTEM, PER CMUD STANDARD DETAILS. SEE INSTALLATION SPECIFICATIONS.
- C. LOCATE 12" ABOVE GROUND MIN. 30" MAX. IN HORIZONTAL DIRECTION. 30" MIN. CLEAR OF ANY PERMANENT OBSTRUCTION. NO MORE THAN 100' UPSTREAM OF NEW METER.
- D. USE TYPE "K" COPPER, D.I.P. (3"-10") OR GALVANIZED STEEL PIPE (1"DIA. MIN.) FROM 5' BEFORE TO 5' PAST ASSEMBLY.
- E. REQUIRED INSULATED PROTECTION 7.4R FACTOR MINIMUM. INSULATION SHALL NOT BE WRAPPED AROUND ASSEMBLY.
- F. LOCATION OF CONNECTION AND BACKFLOW PREVENTION ASSEMBLY WILL BE LOCATED OUTSIDE AND ACCESSIBLE TO CMUD AT ALL TIMES.
- G. IF UNIONS ARE USED (3/4"-2"), CAPS MUST BE PROVIDED AND STORED WITH ASSEMBLY, FOR USE ANY TIME THE ASSEMBLY IS REMOVED. IT IS REQUIRED TO CAP REMAINING PIPING TO SERVICE LINE AND IS SUBJECT TO CMUD INSPECTION AT ANY TIME ASSEMBLY IS REMOVED.
- H. ASSEMBLY REQUIRED TO BE INSTALLED BY A LICENSED PLUMBER OR LICENSED UTILITY CONTRACTOR.

### 2. REQUIREMENTS FOR BACKFLOW PREVENTION ASSEMBLY INSTALLATION WITHIN (EXISTING OR FUTURE) PUBLIC ROAD RIGHT-OF-WAY

- A. ALL CONSTRUCTION ACTIVITIES, AND MATERIALS IN AN EXISTING OR FUTURE PUBLIC ROAD RIGHT-OF-WAY SHALL COMPLY WITH THE CURRENT NC D.O.T. POLICIES AND PROCEDURES FOR ACCOMMODATING UTILITIES ON HIGHWAY RIGHTS OF WAY, OR CDOT POLICIES AND PROCEDURES AND ANY ADDITIONAL REQUIREMENTS OF ACTIVE ENCROACHMENT AGREEMENTS.
- B. NO ASSEMBLIES SHALL BE INSTALLED IN ANY FULLY CONTROLLED OR LIMITED CONTROLLED ACCESS ROADS.
- C. NO BACKFLOW PREVENTION ASSEMBLY SHALL BE INSTALLED ABOVE GROUND IN A PUBLIC ROAD RIGHT-OF-WAY. NOTE ALL REDUCED PRESSURE PRINCIPLE BACKFLOW PREVENTION ASSEMBLY ARE REQUIRED TO BE INSTALLED ABOVE GROUND OUTSIDE OF THE PUBLIC ROAD RIGHT-OF-WAY, AND OUTSIDE ZONING SETBACK AREAS ON PRIVATE PROPERTY.
- D. A DOUBLE CHECK VALVE ASSEMBLY SHALL BE ALLOWED TO BE INSTALLED BELOW GROUND IN A NCDOT APPROVED VAULT. ANY BELOW GROUND INSTALLATION CONFINE WITHIN THE PUBLIC ROAD RIGHT-OF-WAY SHALL BE LOCATED AS NEAR TO RIGHT-OF-WAY LINE AS POSSIBLE. OUTSIDE FACE OF VAULT MUST BE LOCATED NO MORE THAN ONE FOOT INSIDE PUBLIC RIGHT-OF-WAY. VAULT INSTALLATION ARE REQUIRED TO DRAIN TO FREE ATMOSPHERE. NOTE IF DRAINAGE CANNOT BE ACHIEVED, THE DOUBLE CHECK VALVE MUST BE PLACED ABOVE GROUND OUTSIDE THE PUBLIC ROAD RIGHT-OF-WAY, OUTSIDE ZONING SETBACK AREAS ON CUSTOMERS PROPERTY.
- E. ALL CONSTRUCTION SHALL CONFORM TO THE REQUIREMENTS FOR WATER MAIN CONSTRUCTION WITHIN THE JURISDICTION OF THE CHARLOTTE MECKLENBURG UTILITY DEPARTMENT, FROM THE METER TO AND 5 FEET BEYOND THE BACKFLOW PREVENTION ASSEMBLY INSTALLATION.
- F. ASSEMBLY REQUIRED TO BE INSTALLED BY A NC STATE LICENSED PLUMBER OR NC STATE LICENSED UTILITY CONTRACTOR.

## II-PROCEDURES FOR APPROVAL OF INSTALLATION

- A. APPLY FOR NEW LAWN METER AT CMUD.
  - 1) COMPLETE BACKFLOW QUESTIONNAIRE.
  - 2) TURN IN COMPLETED BACKFLOW QUESTIONNAIRE WITH MONEY FOR SERVICE CONNECTION FEES.
  - 3) WITH QUESTIONNAIRE CMUD WILL DETERMINE HAZARD AND SPECIFY ASSEMBLY REQUIRED (R.P. OR D.C.V.A.). CMUD WILL NOTIFY OWNER LISTED ON QUESTIONNAIRE AND BUILDING STANDARDS PLUMBING INSPECTION OF REQUIREMENTS.
- B. ANY INSTALLATION INSTALLED IN (EXISTING OR FUTURE) PUBLIC ROAD RIGHT-OF-WAY, OR SET-BACK AREAS CONTROLLED BY LOCAL AUTHORITIES ARE SUBJECT TO ALL STATE AND LOCAL APPROVALS.
- C. APPLY FOR PLUMBING PERMIT AT BUILDING STANDARDS PLUMBING INSPECTION, AND D.O.T. ENCROACHMENT IF REQUIRED.
- D. FLAG LOCATION FOR CMUD METER.
- E. INSTALL IRRIGATION SYSTEM.
- F. CONTACT BUILDING STANDARDS PLUMBING INSPECTION TO INSPECT INSTALLATION.
- G. WITH APPROVED INSTALLATION CMUD WILL NOTIFY OWNER LISTED ON QUESTIONNAIRE TO SEND A COPY OF THE BACKFLOW PREVENTION ASSEMBLY TEST RECORD. SEE TESTING REQUIREMENTS.



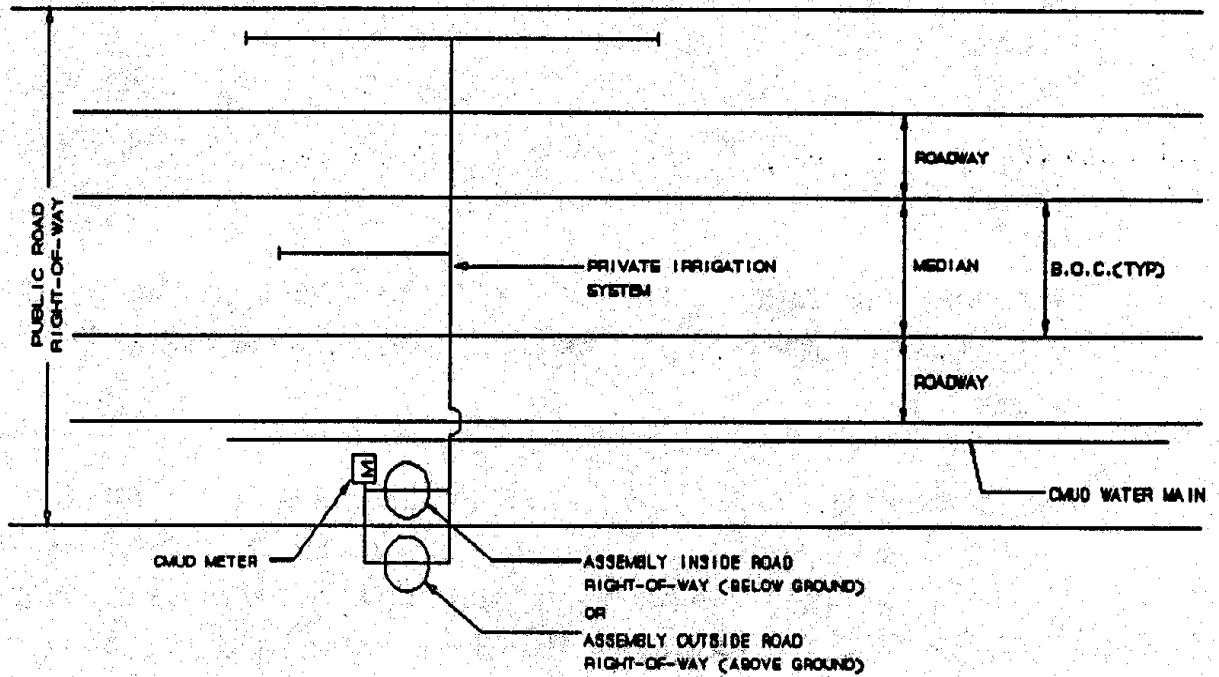

NO ABOVE GROUND INSTALLATIONS  
WITHIN SITE DISTANCE TRIANGLE  
OR WITHIN ZONING SETBACK

### IRRIGATION SYSTEM IN PUBLIC ROAD RIGHT-OF-WAY

## V. APPROVED ASSEMBLIES AND MATERIAL SPECIFICATIONS

All backflow prevention assemblies shall be approved by the University of Southern California Foundation for Cross Connection Control and Hydraulic Research (USCFCCHR), The American Society of Sanitary Engineering (A.S.S.E.), conform to AWWA C506, and adhere to applicable ANSI and ASTM standards. All assemblies installed on fire lines shall have approval by Factory Mutual System (FM).

Backflow prevention assemblies must also be approved by the Charlotte Mecklenburg Utility Department. CMUD will provide a list of approved assemblies.

All internal parts shall be replaceable in line. All internal metal parts shall be bronze or stainless steel. There shall be a minimum of dissimilar metals in an assembly in order to prevent corrosion due to electrolysis. When there are dissimilar metals, the metals shall be electronically similar as possible and insulated if possible.

All assemblies shall have bronze 1/4 turn ball valve test cocks with raised slotted operators or lever type operators. All assemblies shall have four resilient seated test cocks located in the following manner:

1. On the upstream side of the first shut off valve (upstream being the side closest to the property line)
2. Between the first shut off valve and the first check valve.
3. Between the first and second check valve.
4. Between the second check valve and the second shut off valve.

All exterior control piping shall be flexible hose or standard size copper tubing with standard end connections.

All interior control piping or passage ways shall be corrosion resistant. All sensing tubes or passages shall be placed in a manner that prevents clogging or trapping of foreign materials or air.

3/4" - 2" Assemblies shall have bronze or stainless steel bodies and bonnets.

3/4" - 2" Assemblies shall be equipped with shut-off valves that are full port, line size, 1/4 turn, lever type bronze or stainless steel ball valves.

2 1/2 - 10" Assemblies shall have contained check valve modules.

2 1/2 - 10" Assemblies shall be one of the following:  
Fusion bonded epoxy coated cast iron, ductile iron, or steel.  
Bronze bodies and bonnets.  
Stainless steel.

2 1/2" - 10" Assemblies shall be equipped with resilient seated gate, wedge or ball valves with non-rising stem and manual handwheel operators. For fire line installations, the shut-off valves shall be OS & Y gate valves with manual handwheel operators\*

- \* CMUD approved backflow prevention assemblies include shut off valves on each end of the unit.

If special tools or devices are required to repair or maintain an assembly they shall be supplied to the customer by the manufacturer at no extra cost.

An assembly will be removed from the CMUD approved list if it no longer meets CMUD specifications or fails to operate satisfactorily in the field.

CMUD shall be notified in writing of any changes to the design, components, materials, or operation of an assembly. CMUD shall also be notified of any failures, defects or defective material. Failure to do so will result in removal from the CMUD approval list.

Any backflow prevention assembly not on the approved list may be submitted for review and approval by CMUD. If an assembly was previously rejected, it shall not be submitted or resubmitted unless the design has been revised to meet CMUD specifications. Two assemblies shall be submitted for a one-year field evaluation prior to being approved. Shop drawings and specifications of all materials must be furnished as well.

CHARLOTTE MECKLENBURG UTILITY DEPARTMENT  
APPROVED LIST OF BACKFLOW PREVENTION ASSEMBLIES

Double Check Valve Assemblies: 3/4" - 2"

<u>Manufacturer</u>	<u>Size</u>	<u>Model Number</u>
Conbraco	3/4"	40-104-02, 40-104-AZT
	1"	40-105-02, 40-105-AZT
	1 1/2"	40-107-02
	2"	40-108-02
Febco	3/4"	805Y - BV
	1"	805Y - BV
	1 1/2"	805Y - BV
	2"	805Y - BV
Hersey	3/4"	HDC, FDC
	1"	HDC, FDC
	1 1/2"	HDC, FDC
	2"	HDC, FDC
Rainbird	3/4"	DC-QT-075
	1"	DC-QT-100
	1 1/2"	DC-QT-150
	2"	DC-QT-200
Watts	3/4"	709 QT, 007 M1QT
	1"	709 QT, 007 M1QT
	1 1/2"	709 QT, 007 QT
	2"	709 QT, 007 QT
Wilkins	3/4"	550 AB, 950 AB
	1"	550 AB, 950 AB
	1 1/2"	550 AB, 950 AB
	2"	550 AB, 950 AB

Double Check Valve Assemblies: 2 1/2" - 10"

<u>Manufacturer</u>	<u>Size</u>	<u>Model Number</u>
Ames	2 1/2"	2000SS DCA
	3"	2000SS DCA
	4"	2000 DCA OS&Y, 2000SS OS&Y
	6"	2000 DCA OS&Y, 2000SS OS&Y
	8"	2000 DCA OS&Y, 2000SE OS&Y
	10"	2000 DC OS&Y
Conbraco	2 1/2"	40-109-02
	3"	40-100-02
	4"	40-10A-02
	6"	40-10C-02
	8"	40-10E-02
	10"	40-10G-02
Febco	2 1/2"	805YD-RW
	3"	805YD-RW
	4"	805YD-RW
	6"	805YD-RW
	8"	805YD-RW
	10"	805YD-RW
Hersey	3"	No. 2
	4"	No. 2
	6"	No. 2
	8"	No. 2
	10"	No. 2
Watts	2 1/2"	709 RW, 007 RW
	3"	709 RW, 007 RW
	4"	709 RW, 770 RW, 772 RW
	6"	709 RW
	8"	709 RW, 770 RW
	10"	709 RW, 772 RW
Wilkins	2 1/2"	550 R , 950R
	3"	550 R , 950R
	4"	550 R , 950R
	6"	550 R , 950R
	8"	950R

Reduced Pressure Principle Assemblies: 3/4" - 2"

<u>Manufacturer</u>	<u>Size</u>	<u>Model Number</u>
Conbraco	3/4"	40-204-02
	1"	40-205-02
	1 1/2"	40-207-02
	2"	40-208-02
Febco	3/4"	825Y-BV, 825YA-BV
	1"	825Y-BV, 825YA-BV
	1 1/2"	825Y-BV, 825YA-BV
	2"	825Y-BV, 825YA-BV
Hersey	3/4"	FRP II
	1"	FRP II
	1 1/2"	FRP II
	2"	FRP II
Rainbird	3/4"	RP-QT-075
	1"	RP-QT-100
	1 1/2"	RP-QT-150
	2"	RP-QT-200
Watts	3/4"	909 QT, 009M1 QT, 009M2 QT
	1"	909 QT, 009 QT
	1 1/2"	909 M1QT, 009 M1QT
	2"	909 M1QT, 009 M1QT
Wilkins	3/4"	575 AB, 975 AB
	1"	575 AB, 975 AB
	1 1/2"	575 AB, 975 AB
	2"	575 AB, 975 AB

Reduced Pressure Principle Assemblies: 2 1/2" - 10"

<u>Manufacturer</u>	<u>Size</u>	<u>Model Number</u>
Ames	4"	4000 RP OS&Y
	6"	4000 RP OS&Y
	8"	4000 RP OS&Y
	10"	4000 RP OS&Y
Conbraco	2 1/2"	40-209-02
	3"	40-200-02
	4"	40-20A-02
	6"	40-20C-02
	8"	40-20E-02
	10"	40-20G-02
Hersey	2 1/2"	6 CM
	3"	6 CM
	4"	6 CM
	6"	6 CM
Febco	2 1/2"	825D-RW
	3"	825D-RW
	4"	825D-RW
	6"	825D-RW
	8"	825D-RW
	10"	825D-RW
Watts	2 1/2"	909-RW, 009-RW
	3"	909-RW, 009-RW
	4"	909-RW, 990 RW
	6"	909-RW
	8"	909-RW, 990 RW
	10"	909-RW
Wilkins	2 1/2"	575 R, 975R
	3"	575 R, 975R
	4"	575 R, 975R
	6"	575 R, 975R
	8"	975R

## Fire Line Installations

	<u>Sizes</u>	<u>Double Check Valve Assemblies</u>	<u>Reduced Pressure Principle Assemblies</u>
Ames	4", 6" 8" 4"-10"	2000SS OS&Y 2000SE OS&Y 2000 DCA OS&Y	4000 RP OS&Y
Conbraco	4" 6" 8" 10"	40-10A-03 40-10C-03 40-10E-03 40-10G-03	40-20A-03 40-20C-03 40-20E-03 40-20G-03
Febco	4"-10"	805 OS&Y-RW	825 OS&Y
Hersey	4"-10"	No: 2 OS&Y	6 CM OS&Y
Watts	4"-10" 4", 8"	709 OSY-RW 770 OS&Y-RW	909 OSY-RW 990 OS&Y-RW
Wilkins	4"-8"	950R OS&Y	975R OS&Y



## **VI. TESTING REQUIREMENTS**

When assemblies have been installed and approved it is a requirement of the customer to have assemblies tested. Each customer must maintain a complete, written record of every repair and test of all assemblies for a period of at least (7) years. A copy of the record for each test or repair must be sent to CMUD by the customer within (30) days after the completion of each test or repair. Such records must be maintained on forms approved by CMUD. All testing of CMUD regulated backflow prevention assemblies shall be performed by only CMUD approved certified testers using CMUD approved test kits. Refer to requirements of CMUD approved testers and test kits. CMUD will maintain a current list of CMUD approved certified testers and provide this list to the customer.

### **1) NEW SERVICE CONNECTION**

The customer is required to test the backflow prevention assembly upon installation. The customer is required to submit satisfactory test results to CMUD within 30 days upon notification from CMUD. The customer is required to test the backflow prevention assembly and submit to CMUD satisfactory test results annually thereafter. The test results shall be submitted on CMUD approved test forms.

### **2) EXISTING SERVICE CONNECTION**

The customer is required to test the backflow prevention assembly upon installation as outlined in the Backflow Prevention and Cross Connection Control Ordinance. The customer is required to submit satisfactory test results to CMUD within 30 days upon notification from CMUD. The customer is required to test the backflow prevention assembly and submit to CMUD satisfactory test results annually thereafter. The test results shall be submitted on CMUD approved test forms.

In the event an assembly requires repairs before an annual test period, the customer is required to have repairs made immediately. As soon as repairs have been completed the customer must have a CMUD approved certified tester conduct a test showing the assembly is in good working order. Any repairs made shall be with manufacturer approved parts. All work shall be documented with a copy of the satisfactory test and repair records sent to CMUD.

Testing for assemblies on fire protection systems must include standard operating procedures during the testing process. The customer is responsible for notifying any affected parties that the fire system will be shut down (i.e. alarm company, insurance carrier, fire official).

The customer may be required to have an approved plan to protect life and property during any period of time a fire system is out of service. Standard Operating Procedures should be written by the customer and should be approved by the fire official for use in the event of an emergency. No customer shall allow any testing to begin until such procedures are in place

and effective. It is the responsibility of the customer to provide safety for life and property during the entire test or repair. **The customer is required to meet all code and regulations as imposed by the governing fire official.**

## **VII. REQUIREMENTS FOR CERTIFIED TESTER**

Any person interested in becoming an approved certified tester must request to CMUD in writing to become a CMUD approved certified tester. The letter shall include full name, mailing address, phone number they can be reached between 8am and 5pm, and the name of school certification was obtained from. The tester must attend an orientation conducted by CMUD. CMUD will conduct an orientation periodically where the tester will be required to provide evidence of a valid certificate of training in backflow prevention assembly testing and maintenance from one of the schools listed on the current list of CMUD approved schools. During the orientation CMUD will provide the tester with information on the current testing program. The tester will have the following requirements:

1. The tester must have knowledge and understanding of the City of Charlotte Backflow Prevention ordinance Article V of Chapter 23 of the city code. The tester is required to keep abreast of the current CMUD requirements and specifications in the current Backflow Prevention Program Manual. Any violation of the ordinance may result in civil penalties as outlined in the ordinance.
2. The tester must understand and strictly adhere to testing procedures ASSE-5010-1015-1 for double check valve assembly and ASSE-5010-1013-1 for reduced pressure principle backflow prevention assemblies as listed in the American Society of Sanitary Engineering Professional Qualification Standard or the current procedures listed in the most current edition of the Manual Of Cross-Connection Control by the University of Southern California Foundation For Cross-Connection Control And Hydraulic Research.
3. No tester is allowed to conduct any test without the customers full consent and cooperation. Any tester conducting a test on fire protection systems must consult the owner on standard operating procedures during the testing process. No tester shall allow any testing to begin until such procedures are in place and effective. It is the responsibility of the tester to make sure the customer can provide safety for life and property during the entire test or repair. If the customer cannot provide this measure of safety the test is not to be completed until these safety requirements are met. **The tester is required to meet all code and regulations as imposed by the governing fire official. See Bulletin #8 GUIDELINES FOR TESTING BACKFLOW PREVENTION ASSEMBLIES ON FIRELINES.**

4. The tester shall agree to keep their certification current by completing recertification on or before the date their current certificate expires. Any laps in certification shall be reported to CMUD. Failure to report laps or loss of certification may result in penalties as outlined in the ordinance.
5. The tester is required to use only CMUD approved test kits which have been registered with CMUD. (Refer to requirements for CMUD approved test kits). The tester must agree to abide by requirements for test kits.
6. Any work completed by the tester to achieve satisfactory test results for the customer must be documented on CMUD approved test forms. All parts used to repair or overhaul a backflow prevention assembly must be recommended for use by that approved manufacturer for that particular application only. No tester shall be allowed to substitute any other manufacturer's products for the use in another manufacturer's product.
7. A tester is required to report any nonstandard installation not conforming with CMUD standard details and specifications. This can be done in the comments portion of test the form.
8. It is required that the tester provide the customer with accurate and complete test records. The customer will be responsible for submitting the completed CMUD approved test form with satisfactory test results including information of any necessary repairs.
9. It will be the responsibility of the tester to make safe or require the customer to provide a safe working environment. Precautions must be taken with hazards related but not limited to:
  - Confined space
  - Vehicle traffic
  - Insect and animals
  - Tool utilized, etc.
10. The tester shall never place any person or property in any danger such as fire or water contamination during the testing of any assembly. Tester must sign the certified tester agreement and comply with exhibit A therewith. If the tester fails to comply with the agreement, CMUD certification may be revoked.
11. Falsification of records, or failure to meet any of the requirements as outlined will result in removal from approved certified tester list and/or penalties as outlined in ordinance.

12. The tester will be required to sign an agreement with CMUD stating his/her responsibilities as a CMUD certified tester.

### **VIII. REQUIREMENTS FOR TEST KITS**

Any person approved as a certified tester by CMUD is required to use a CMUD approved test kit. An approved test kit will meet and be approved by the current requirements of the University of Southern California Foundation for Cross-Connection Control and Hydraulic Research standards for differential pressure gauges or duplex gauges. Each kit will have the following requirements:

1. The test kit is required to be an approved test kit listed on the current list of CMUD approved backflow prevention assembly test kits.
2. Each kit must be registered with CMUD with a current calibration certificate (less than 1 yr. old). All test kits approved to test CMUD regulated backflow prevention assemblies will be registered with the following:

Manufacturer of kit  
Type of kit ( Duplex / Differential )  
Serial number  
Owner - name, address, and phone  
Calibration Date

3. All registered test kits are required to be recalibrated annually. CMUD will notify owner in writing when recalibration certificate is due. The Recalibration certificate signed by a technician shall be submitted to CMUD by the owner within 30 days. The technician calibrating the test kit shall use the most current edition of the Manual Of Cross-Connection Control from the University of Southern California Foundation for Cross-Connection Control and Hydraulic Research Section 9.5.1, 9.5.2, and 9.5.3 to do a differential pressure gage calibration check and duplex pressure gage calibration check as well as section 6 of the ANSI/ASME Standard B40.1-1985 for pressure gage testing.
4. All registered test kits shall be kept in accurate working order. All repairs shall be made immediately and recalibration is required with a current certificate to be submitted to CMUD upon completion of the repair. Failure to notify CMUD of a malfunctioning tests kit will cause it to be removed from the approved list.

5. Upon request any CMUD approved test kit shall be operated in the presence of a CMUD representative. If repairs are required, a certification of calibration shall be submitted to CMUD showing repairs have been completed and the test kit is in good operating order.
6. CMUD will remove or disapprove any test kit which does not comply with the current requirements of this policy.

**IX. CHARLOTTE MECKLENBURG UTILITY DEPARTMENT APPROVED  
BACKFLOW PREVENTION ASSEMBLY TESTING EQUIPMENT**

<u>Manufacturer</u>	<u>Model</u>
Duke	75
Duke	100
ITT Barton	100 BFT
ITT Barton	100 BFT
Midwest Instrument	830
Midwest Instrument	890
Watts	TK-DP
Watts	TK-DR
Conbraco	40-100-TK
Conbraco	40-200-TK

**X. CHARLOTTE-MECKLENBURG UTILITY DEPARTMENT APPROVED  
TESTERS SCHOOLS**

Fayetteville Public Works Commission P. O. Box 1089 Fayetteville, NC 28302 Mr. Ronnie West - Coordinator (919) 483-1401 Ext. 439	City of Raleigh Department of Public Utilities P. O. Box 590 Raleigh, NC 27602 Mr. Ben Yarborough - Coordinator (919) 831-6527
--	---

University of Southern California Foundation For Cross-connection Control and Hydraulic Research School of Engineering BHE - 315 University park MC-0231 Los Angeles, California 90089-0231 Mr. Paul H. Schwartz, P. E. - Coordinator (213) 743-2032	Charlotte Mecklenburg Utilities System Protection Division Backflow Prevention 5100 Brookshire Blvd. Charlotte, NC 28216 Mr. Mark A. Krouse-COordinator (704) 391-5159
--	--

University of Florida  
Center For Training Research and Education  
For Environmental Occupations (TREEO)  
3900 SW 63rd Boulevard  
Gainesville, Florida 32608 (904) 392-9570

**CHARLOTTE MECKLENBURG BUILDING STANDARDS DEPARTMENT  
PHONE LIST:**

ASSISTANT PLUMBING CODE ADMINISTRATOR

DONNIE TAYLOR 336-3556

PLANS REVIEW FACILITATOR

MICHAEL BURKHARD 336-3836  
PATRICK GRANDSON 336-

CO. FIRE PLAN REVIEW

BEN AYCOCK 336-3808

CITY FIRE PLAN REVIEW

RANDY TURNER 336-3814  
CLEVELAND HUNTLEY 336-3812

PLUMBING PLAN REVIEW

WILLIS HORTON 336-4301  
CHARLIE SUTTON 336-3838

STRUCTURAL PLAN REVIEW

WILLIAM RAKATANSKY 336-4302

ZONING PLAN REVIEW

KAM MERRELL 336-3813  
SAM McCOY 336-

\*\*\*\*\* CHAR.-MECK. BLDG. STD. FAX # 336-3839 \*\*\*\*\*

CMUD 399-2551  
MARK A. KROUSE FAX # 393-2219  
391-5100

BULLETIN #8  
GUIDELINES FOR TESTING OF  
BACKFLOW PREVENTION ASSEMBLIES ON FIRE LINES  
**(Requirements of fire official)**

1. TESTERS WILL BE ALLOWED TO SHUT DOWN WATER SUPPLY TO FIRE LINES FOR NO MORE THAN ONE HOUR PER ASSEMBLY. FIRE LINES SHUT DOWN FOR MORE THAN ONE HOUR FOR BFPA TESTING OR REPAIR PURPOSES, WILL RESULT IN THE TESTER BEING SUBJECT TO ALL FINES, PENALTIES OR ARREST.
2. TESTS OR REPAIRS REQUIRING LONGER SHUT DOWN TIME, WILL REQUIRE A REPLACEMENT BFPA TO BE INSTALLED.
3. TESTING OR REPAIRS WILL BE DONE AT TIMES DURING LOWEST PEDESTRIAN OCCUPANCY. (SEE BELOW)
4. ADDITIONAL PERMITTING FOR THE TESTING OF FIRE LINES WILL BE REQUIRED FOR TESTERS.
5. A 15 DAY ITINERARY WILL BE SUBMITTED BY ALL FIRE PREVENTION BUREAU PERMITTED TESTERS.
6. IN THE EVENT OF LONG TERM IMPAIRMENT OF THE FIRE LINE SYSTEM, ADDITIONAL CHARGES MAY BE LEVIED AGAINST THE PROPERTY OWNER.

TEST TIMES FOR BACKFLOW PREVENTION DEVICES PER OCCUPANCY

1. HIGH RISE - AFTER 6:00 PM, WEEKENDS, HOLIDAYS
2. MALLS - AFTER CLOSING HOURS
3. SCHOOLS - AFTER CLASSES OR SUMMERTIME
4. HOSPITALS & JAILS - BEFORE OR AFTER VISITING HOURS
5. INDUSTRIAL & WAREHOUSE - PREFERABLY AFTER NORMAL OPERATING HOURS OR DURING LOWEST OCCUPANCY (2ND OR 3RD SHIFT)

FIRE PREVENTION BUREAU - 336-2101

ALARM (AFTER HOURS) - 336-2578



## APPROVED FIELD TEST PROCEDURES FOR BACKFLOW PREVENTION ASSEMBLIES

### PREPARATION

1. OBTAIN PERMISSION FROM THE OWNER OR REPRESENTATIVE TO SHUT DOWN THE WATER SUPPLY. JUST PRIOR TO TESTING, THE CUSTOMER SHOULD BE NOTIFIED THAT THE WATER SERVICE WILL BE DISCONTINUED TEMPORARILY

**\*\*\* IF A FIRE LINE IS SUPPLIED BY THE SERVICE WITH BACKFLOW ASSEMBLY BEING TESTED THE APPROPRIATE OFFICIALS MUST BE NOTIFIED OF THE SHUT DOWN. THE TESTER IS REQUIRED TO MEET ALL CODE AND REGULATIONS AS IMPOSED BY THE GOVERNING FIRE OFFICIAL. SEE BULLETIN #8 GUIDELINES FOR TESTING BACKFLOW PREVENTION DEVICES ON FIRE LINES.**

2. OBSERVE AND RECORD THE PHYSICAL CONDITIONS OF THE ASSEMBLY AND SURROUNDING AREA. OBSERVE THE DIRECTION OF FLOW. **IS THIS THE CORRECT ASSEMBLY FOR ITS APPLICATION ?**

3. RECORD OR VERIFY THE FOLLOWING INFORMATION ON EACH ASSEMBLY:

MANUFACTURER  
MODEL  
SERIAL #  
SIZE OF ASSEMBLY  
LOCATION OF ASSEMBLY

4. DETERMINE WHICH TEST KIT IS REQUIRED FOR ASSEMBLY BEING TESTED  
REDUCED PRESSURE PRINCIPLE ASSEMBLY REQUIRES A DIFFERENTIAL GAUGE  
DOUBLE CHECK VALVE ASSEMBLY REQUIRES A DUPLEX GAUGE
5. REMOVE ANY LODGED FOREIGN MATERIAL THAT MIGHT INTERFERE WITH TEST. FLUSH TEST COCKS BY OPENING #4 TEST COCK TO MAINTAIN FLOW THROUGH ASSEMBLY, THEN OPEN AND CLOSE TEST COCK #1, #2, #3, THEN CLOSE #4 TEST COCK. ATTACH APPROPRIATE FITTINGS TO TEST COCKS THEN FOLLOW TEST STEPS OUTLINED FOR PARTICULAR ASSEMBLY.

STEP-BY-STEP TESTING PROCEDURES FOR  
REDUCED PRESSURE PRINCIPLE ASSEMBLY

PURPOSE 1 TO VERIFY THAT A MINIMUM OF 5.0 psi IS MAINTAINED ACROSS CHECK VALVE #1.  
2 TO CHECK THAT THE RELIEF VALVE OPENING IS AT OR ABOVE 2.0 psi.  
3 TO VERIFY THAT THE CHECK VALVE #2 WILL HOLD TIGHT AGAINST BACKPRESSURE.  
4 TO VERIFY THAT A MINIMUM OF 1.0 psi IS MAINTAINED ACROSS CHECK VALVE #2.

- 1) FOLLOW PREPARATION STEPS, OPERATING TEST COCK #2 **VERY** SLOWLY. ATTACH THE HIGH PRESSURE HOSE TO TEST COCK #2 AND THE LOW PRESSURE HOSE TO TEST COCK #3. THE HIGH CONTROL VALVE SHOULD BE OPEN ON TEST KIT. **IT CAN REMAIN OPEN THROUGHOUT ALL FOUR TESTS.** THE LOW CONTROL VALVE AND THE BYPASS CONTROL VALVE SHOULD BE CLOSED.
- 2) OPEN THE HIGH AND LOW BLEED VALVES, THEN SLOWLY OPEN TEST COCK #3 AND #2, THIS WILL BLEED AIR FROM TEST KIT AND ASSEMBLY. IT IS IMPORTANT THAT THE TEST COCKS BE OPENED IN THIS ORDER TO PREVENT THE RELIEF VALVE FROM OPENING.
- 3) CLOSE HIGH BLEED VALVE, THEN CLOSE THE LOW BLEED VALVE. **CLOSE LOW LAST.** CLOSE #2 SHUT-OFF, OBSERVE DIFFERENTIAL PRESSURE ACROSS CHECK VALVE #1. **THIS READING SHOULD BE GREATER THAN 5.0 psi.**
- 4) OPEN LOW CONTROL VALVE **ONE QUARTER TURN ONLY.** RECORD THE OPENING POINT OF THE RELIEF VALVE WHEN WATER BEGINS TO DRIP FROM THE ASSEMBLY. **THIS READING SHOULD BE GREATER THAN 2.0 psi.** CLOSE THE LOW CONTROL VALE.
- 5) OPEN THE BY PASS CONTROL VALVE AND BLEED AIR FROM HOSE. LOOSELY ATTACH BYPASS HOSE TO TEST COCK #4. CLOSE BYPASS CONTROL VALVE AND TIGHTEN BYPASS LINE. OPEN TEST COCK #4.
- 6) OPEN LOW BLEED VALVE, AND THEN CLOSE LOW BLEED VALVE. OPEN BYPASS CONTROL VALVE, THE DIFFERENTIAL SHOULD REMAIN AT OR ABOVE 5.0 psi. RECORD STATUS OF CHECK VALVE #2 (LEAKED, OR HELD TIGHT). CLOSE BY-PASS CONTROL VALVE, OPEN LOW BLEED TO REESTABLISH ACCURATE PRESSURE READING ACROSS CHECK VALVE #1, CLOSE LOW BLEED.
- 7) RECORD GAUGE READING. THIS IS THE DIFFERENTIAL PRESSURE ACROSS CHECK VALVE #1. CLOSE TEST COCK #2, #3, THEN TEST COCK #4. BLEED TEST KIT, CLOSE BY-PASS CONTROL VALVE ON TEST KIT. REMOVE HOSES.
- 8) ATTACH HIGH HOSE TO TEST COCK #3, AND LOW TO TEST COCK #4. OPEN HIGH AND LOW BLEED VALVES. OPEN TEST COCK #4 THEN TEST COCK #3. BLEED TEST KIT, CLOSE HIGH BLEED VALVE, THEN CLOSE LOW BLEED VALVE LAST.
- 9) RECORD GAUGE READING. THIS IS THE DIFFERENTIAL PRESSURE AT CHECK VALVE # 2. **THIS READING SHOULD BE GREATER THAN 1.0 psi.** CLOSE TEST COCK #4 AND TEST COCK #3.
- 10) **OPEN SHUT OFF VALVE #2.** OPEN ALL CLOSED BLEED, AND CONTROL VALVES AND DRAIN TEST KIT. REMOVE HOSES. NOTIFY CUSTOMER WATER SERVICE IS BACK ON.

BACKFLOW PREVENTER TESTING AND MAINTENANCE  
TROUBLE SHOOTING GUIDE  
**REDUCED PRESSURE PRINCIPLE ASSEMBLY**

**NOTE: MANY PROBLEMS CAN BE CORRECTED BY CLEANING THE INTERNAL COMPONENTS. CAREFULLY OBSERVE CONDITION OF ALL COMPONENTS.**

PROBLEM	MAY BE CAUSED BY
RELIEF VALVE DISCHARGES CONTINUOUSLY.	<ol style="list-style-type: none"> <li>1. FAULTY CHECK VALVE #1.</li> <li>2. FAULTY CHECK VALVE #2 WITH BACK-PRESSURE CONDITION.</li> <li>3. FAULTY RELIEF VALVE.</li> </ol>
RELIEF VALVE DISCHARGES INTERMITTENTLY.	<ol style="list-style-type: none"> <li>1. PROPERLY WORKING ASSEMBLY WITH BACK SIPHONAGE CONDITION.</li> <li>2. CHECK VALVE #1 "BUFFER" IS TOO SMALL (i.e. LESS THAN 3.0 psi), WITH LINE PRESSURE FLUCTUATION.</li> <li>3. WATER HAMMER.</li> </ol>
RELIEF VALVE DISCHARGES AFTER #2 SHUT-OFF VALVE IS CLOSED. (STEP 3)	<ol style="list-style-type: none"> <li>1. NORMALLY INDICATES FAULTY CHECK VALVE #1.               <ol style="list-style-type: none"> <li>a. DIRTY OR DAMAGED DISC.</li> <li>b. DIRTY OR DAMAGED SEAT.</li> </ol> </li> </ol>
RELIEF VALVE WOULD NOT OPEN, DIFFERENTIAL ON THE GAUGE WOULD NOT DROP. (STEP 4)	<ol style="list-style-type: none"> <li>1. LEAKY #2 SHUT-OFF VALVE WITH FLOW THROUGH THE ASSEMBLY.</li> </ol>
RELIEF VALVE WOULD NOT OPEN, DIFFERENTIAL DROPS TO ZERO. (STEP 4)	<ol style="list-style-type: none"> <li>1. RELIEF VALVE STUCK CLOSED DUE TO CORROSION OR SCALE.</li> <li>2. RELIEF VALVE SENSING LINE PLUGGED.</li> </ol>
RELIEF VALVE OPENS TOO HIGH. (WITH SUFFICIENTLY HIGH CHECK VALVE #1 READING OBSERVED) (STEP 4)	<ol style="list-style-type: none"> <li>1. FAULTY RELIEF VALVE.               <ol style="list-style-type: none"> <li>a. DIRTY OR DAMAGED DISC.</li> <li>b. DIRTY OR DAMAGED SEAT.</li> </ol> </li> </ol>
CHECK VALVE #1 READING TOO LOW. (LESS THAN 3.0 psi "BUFFER") (STEP 7)	<ol style="list-style-type: none"> <li>1. DIRTY OR DAMAGED DISC.</li> <li>2. DIRTY OR DAMAGED SEAT.</li> <li>3. GUIDE MEMBERS HANGING UP.</li> <li>4. WEAK OR BROKEN SPRING.</li> </ol>
LEAKY #2 CHECK VALVE.	<ol style="list-style-type: none"> <li>1. DIRTY OR DAMAGED DISC.</li> <li>2. DIRTY OR DAMAGED SEAT.</li> <li>3. GUIDE MEMBERS HANGING UP.</li> <li>4. WEAK OR BROKEN SPRING.</li> </ol>

**REPAIR NOTE: LUBRICANTS SHALL ONLY BE USED TO ASSIST WITH THE REASSEMBLY OF COMPONENTS, AND SHALL NOT BE TOXIC. USE ONLY FOOD-GRADE LUBRICANTS.**

## STEP-BY-STEP TESTING PROCEDURES FOR DOUBLE CHECK VALVE ASSEMBLY

PURPOSE 1 TO VERIFY THAT #1 AND (#2) CHECK VALVE WILL HOLD TIGHT AGAINST BACK PRESSURE.

2 CONFIRMATION TEST WILL VERIFY WHETHER CHECK VALVE WILL HOLD TIGHT AGAINST BACK PRESSURE AND TO DETERMINE WHETHER EITHER SHUT-OFF VALVES LEAKS.

### **INSTRUCTIONS FOR TESTING CHECK VALVE #2 ARE IN PARENTHESES ( )**

- 1) FOLLOW PREPARATION STEPS. ATTACH THE HIGH PRESSURE HOSE TO TEST COCK #2 (#3) AND THE LOW PRESSURE HOSE TO TEST COCK #3 (#4).
- 2) OPEN THE HIGH BLEED AND LOW CONTROL VALVES, THEN CLOSE THE VALVES. CLOSE #2 SHUT-OFF VALVE. CLOSE THE #1 SHUT-OFF VALVE.
- 3) OPEN THE HIGH BLEED VALVE AND REDUCE THE PRESSURE ON THE SUPPLY SIDE TO 2 psi LESS THAN THE PRESSURE ON THE CUSTOMER SIDE.
- 4) OBSERVE WHETHER THE 2 psi SPLIT BETWEEN THE NEEDLES IS MAINTAINED AND RECORD. IF NEEDLES HOLD 2 psi SPLIT CHECK VALVE #1 (#2) IS HOLDING TIGHT. CLOSE ALL TEST COCKS. **OPEN #1 SHUT-OFF VALVE**. REPEAT STEPS FOR CHECK VALVE #2. **OPEN #1 AND #2 SHUT-OFF VALVE**. REMOVE HOSES.
- 5) IF SPILT ISN'T MAINTAINED OR IF THERE IS ANY QUESTION ON THE RESULTS OF THIS TEST, DO CONFIRMATION TEST.

### CONFIRMATION TEST

- 6) OPEN #1 SHUT-OFF VALVE. OPEN LOW CONTROL VALVE TO REMOVE AIR FROM BYPASS HOSE. CONNECT BYPASS HOSE TO THE TEST COCK #1 AND CLOSE LOW CONTROL VALVE OPEN TEST COCK #1.
- 7) CLOSE #1 SHUT-OFF VALVE. LOOSEN THE HOSE CONNECTION AT TEST COCK #3 (#4) TO LOWER PRESSURE IN ASSEMBLY AT LEAST 10 psi. OPEN BOTH HIGH AND LOW CONTROL VALVES SIMULTANEOUSLY AND REDUCE SUPPLY SIDE BY 2.5 psi AND INCREASE CUSTOMER SIDE BY 2.5 psi.
- 8) OBSERVE WHETHER THE 5.0 psi SPLIT IS MAINTAINED, RECORD RESULTS. IF SPLIT CAN BE MAINTAINED WITH CONTROL VALVES CLOSED, CHECK HOLDS TIGHT IF NOT SEE TROUBLE SHOOTING GUIDE.
- 9) CLOSE ALL TEST COCKS. **OPEN #1 AND #2 SHUT-OFF VALVE**. REMOVE HOSES, AND NOTIFY CUSTOMER WATER SERVICE IS BACK ON.

BACKFLOW PREVENTER TESTING AND MAINTENANCE  
TROUBLE SHOOTING GUIDE  
**DOUBLE CHECK VALVE ASSEMBLY**

**NOTE: MANY PROBLEMS CAN BE CORRECTED BY CLEANING THE INTERNAL COMPONENTS. CAREFULLY OBSERVE CONDITION OF ALL COMPONENTS.**

PROBLEM	MAY BE CAUSED BY
DURING CONFORMATION TEST NEEDLES ON TEST KIT BOTH INCREASE IN PRESSURE.	#1 SHUT-OFF VALVE LEAKS.
DURING CONFORMATION TEST NEEDLES BOTH FALL TO ZERO.	#2 SHUT-OFF VALVE LEAKS. (NO BACK PRESSURE EXISTS)
DURING CONFORMATION TEST NEEDLES CONVERGE.	CHECK VALVE LEAKS.
LEAKY CHECK VALVE	<ol style="list-style-type: none"> <li>1. DIRTY OR DAMAGED DISC.</li> <li>2. DIRTY OR DAMAGED SEAT.</li> <li>3. GUIDE MEMBERS HANGING UP.</li> <li>4. WEAK OR BROKEN SPRING.</li> </ol>

**REPAIR NOTE: LUBRICANTS SHALL ONLY BE USED TO ASSIST WITH THE REASSEMBLY OF COMPONENTS, AND SHALL NOT BE TOXIC. USE ONLY FOOD-GRADE LUBRICANTS.**

RESULTS OF THE CONFIRMATION TEST ON THE DOUBLE CHECK VALVE ASSEMBLY. THE MOVEMENT OF THE TWO DUPLEX GAUGE NEEDLES WILL INDICATE WHETHER THE CHECK VALVE IS HOLDING TIGHT AGAINST BACK PRESSURE AND, WHETHER ONE OF THE SHUT-OFF VALVES IS LEAKING.

This page intentionally left blank.

**CITY OF CHARLOTTE**  
**CHARLOTTE-MECKLENBURG UTILITY DEPARTMENT**  
**CROSS CONNECTION CONTROL AND BACKFLOW**  
**PREVENTION PROGRAM QUESTIONNAIRE**

PROPERTY OWNER:  
 FIRST NAME: \_\_\_\_\_ LAST NAME: \_\_\_\_\_  
 COMPANY NAME: \_\_\_\_\_  
 ADDRESS: \_\_\_\_\_ PHONE: \_\_\_\_\_  
 CITY: \_\_\_\_\_ STATE: \_\_\_\_\_ ZIP CODE: \_\_\_\_\_

TENANT NAME (if different): \_\_\_\_\_  
 ADDRESS: \_\_\_\_\_ PHONE: \_\_\_\_\_  
 CITY: \_\_\_\_\_ STATE: \_\_\_\_\_ ZIP CODE: \_\_\_\_\_

CONTACT COMPANY NAME: \_\_\_\_\_  
 CONTACT NAME: \_\_\_\_\_  
 ADDRESS: \_\_\_\_\_ PHONE: \_\_\_\_\_  
 CITY: \_\_\_\_\_ STATE: \_\_\_\_\_ ZIP CODE: \_\_\_\_\_

ADDRESS OF PROPERTY: \_\_\_\_\_  
 CITY: \_\_\_\_\_ ZIP CODE \_\_\_\_\_

1. Type of facility (i.e., commercial, industrial, medical, institutional): \_\_\_\_\_
2. Type of operation (i.e., retail container co., warehouse, mfg plant): \_\_\_\_\_

Please list Standard Industrial Code (S.I.C. #): \_\_\_\_\_

3. List type(s) equipment used in your facility (i.e., chemical feed tanks, mixing vats, dishwashers, booster pumps, cooling towers): \_\_\_\_\_

- |  |     |    |
|--|-----|----|
| 4. Is there any mixing of water and other substances in your operation?  | YES | NO |
| 5. Are there any toxic chemicals used in your operation?   | YES | NO |
| 6. Does your cooling system utilize recycled water?  | YES | NO |
| 7. Are there any other sources of water to your property for fire protection or additional storage (i.e., private well, elevated storage fed from a well)? | YES | NO |
| 8. Is this service for lawn irrigation only?   | YES | NO |
| WILL SYSTEM USE CHEMICALS?   | YES | NO |

This questionnaire must be submitted with payment of water service connection fee. The information on this questionnaire will assist in determining the hazard classification of your facility. In the event that the information provided is inaccurate or changes, the hazard classification and the type of backflow prevention assembly required may be revised. If no information can be provided, the location will be classified as a high hazard. If you have any questions, please contact the Cross Connection Control Section at (704) 399-2551. Keep a copy for your records.

COMPLETED BY PUBLIC SERVICE: \_\_\_\_\_

COMPLETED BY SYSTEMS & RECORDS: \_\_\_\_\_

DEVELOPER INSTALLED METER ( Y/N ) ? \_\_\_\_\_  
 CMUD PROJECT NAME: \_\_\_\_\_  
 CMUD JOB NUMBER: \_\_\_\_\_  
 DATE: \_\_\_\_\_  
 SERVICE # \_\_\_\_\_  
 METER SIZE: \_\_\_\_\_  
 TOPO NUMBER: \_\_\_\_\_  
 NUMBER OF SERVICES @ ADDRESS: \_\_\_\_\_  
 DOMESTIC, FIRE LINE, COMBINATION  
 OR IRRIGATION: \_\_\_\_\_

\_\_\_\_\_ HIGH OR MODERATE HAZARD  
 \_\_\_\_\_ DCVA OR RBPBA  
 \_\_\_\_\_ ASSESSMENT DATE  
 \_\_\_\_\_ NEW OR EXISTING SERVICE

**CITY OF CHARLOTTE**  
**CHARLOTTE-MECKLENBURG UTILITY DEPARTMENT**  
**BACKFLOW PREVENTER**  
**TEST AND MAINTENANCE REPORT**

CUSTOMER: \_\_\_\_\_  
 ADDRESS OF PROPERTY: \_\_\_\_\_  
 MAILING ADDRESS: \_\_\_\_\_  
 LOCATION OF ASSEMBLY: \_\_\_\_\_

TYPE OF ASSEMBLY: RP- DC- PVB  SIZE: \_\_\_\_\_

MANUFACTURER: \_\_\_\_\_ MODEL: \_\_\_\_\_ SERIAL NO. \_\_\_\_\_  
 TIME OF TEST: \_\_\_\_\_

TYPE OF SERVICE:  
 DOM.  IRRIG.  F.L.  COMBINATION (DOM. & F.L.)

CHECK VALVE #1	RELIEF VALVE	CHECK VALVE #2	PRESSURE VACUUM BREAKER
<input type="checkbox"/> LEAKED <input type="checkbox"/> CLOSED TIGHT  DIFF. PRESSURE ACROSS CHECK VALVE _____ PSID	OPENED AT _____ PSID  DID NOT OPEN <input type="checkbox"/>	<input type="checkbox"/> LEAKED <input type="checkbox"/> CLOSED TIGHT DIFF. PRESSURE ACROSS CHECK VALVE _____ PSID	AIR INLET OPENED AT _____ PSID DIDN'T OPEN <input type="checkbox"/> CHECK VALVE: LEAKED <input type="checkbox"/> HELD AT _____ PSID
<input type="checkbox"/> CLEANED ONLY  REPLACED: RUBBER KIT <input type="checkbox"/> CV ASSEMBLY <input type="checkbox"/> OR DISC <input type="checkbox"/> O-RINGS <input type="checkbox"/> SEAT <input type="checkbox"/> SPRING <input type="checkbox"/> STEM/GUIDE <input type="checkbox"/> RETAINER <input type="checkbox"/> LOCK NUTS <input type="checkbox"/> OTHER <input type="checkbox"/>	<input type="checkbox"/> CLEANED ONLY  REPLACED: RUBBER KIT <input type="checkbox"/> RV ASSEMBLY <input type="checkbox"/> OR DISC <input type="checkbox"/> O-RINGS <input type="checkbox"/> SEAT <input type="checkbox"/> SPRING <input type="checkbox"/> GUIDE <input type="checkbox"/> DIAPHRAGM <input type="checkbox"/> OTHER <input type="checkbox"/>	<input type="checkbox"/> CLEANED ONLY  REPLACED: RUBBER KIT <input type="checkbox"/> CV ASSEMBLY <input type="checkbox"/> OR DISC <input type="checkbox"/> O-RINGS <input type="checkbox"/> SEAT <input type="checkbox"/> SPRING <input type="checkbox"/> STEM/GUIDE <input type="checkbox"/> RETAINER <input type="checkbox"/> LOCK NUTS <input type="checkbox"/> OTHER <input type="checkbox"/>	<input type="checkbox"/> CLEANED ONLY  REPLACED: RUBBER KIT <input type="checkbox"/> CV ASSEMBLY <input type="checkbox"/> DISC, AIR <input type="checkbox"/> DISC, CV <input type="checkbox"/> SPRING, AIR <input type="checkbox"/> SPRING, CV <input type="checkbox"/> RETAINER <input type="checkbox"/> GUIDE <input type="checkbox"/> O-RING <input type="checkbox"/> OTHER <input type="checkbox"/>
<input type="checkbox"/> CLOSED TIGHT  DIFF. PRESSURE ACROSS CHECK VALVE _____ PSID	OPENED AT _____ PSID	<input type="checkbox"/> CLOSED TIGHT  DIFF. PRESSURE ACROSS CHECK VALVE _____ PSID	AIR INLET _____ PSID  CHECK VALVE _____ PSID

**NOTE: ALL REPAIRS MUST BE COMPLETED WITHIN (10) DAYS.**

REMARKS: \_\_\_\_\_  
 \_\_\_\_\_  
 \_\_\_\_\_

I HEREBY CERTIFY THAT THIS DATA IS ACCURATE AND REFLECTS THE PROPER OPERATION AND MAINTENANCE OF THE ASSEMBLY.

TESTER: \_\_\_\_\_ CERT. NO.: \_\_\_\_\_ DATE: \_\_\_\_\_  
 TEST KIT: DIFFERENTIAL  DUPLEX  ELECTRONIC

CERT. NO.: \_\_\_\_\_ MANUFACTURER: \_\_\_\_\_



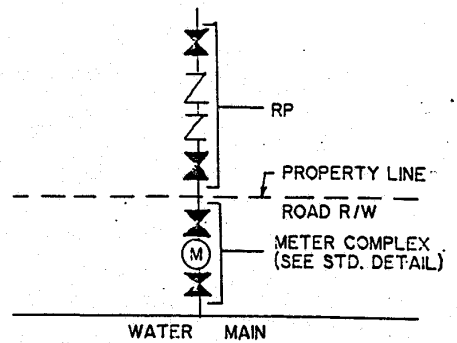
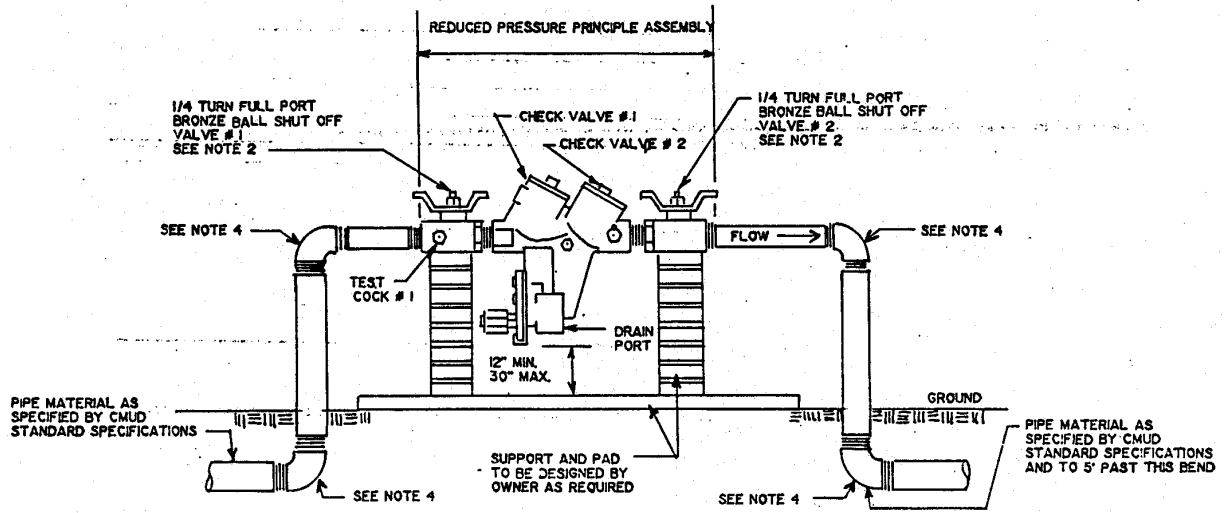

**NOTES**

1. REDUCED PRESSURE PRINCIPLE ASSEMBLIES (RP) MUST CONFORM TO CMUD SPECIFICATIONS.
2. THE CMUD APPROVED 3/4" - 2" RP INCLUDES SHUT OFF VALVES # 1 AND # 2 AS PART OF THE ASSEMBLY. NO SUBSTITUTIONS SHALL BE PERMITTED.
3. IF OUTDOOR INSTALLATION HAS PROTECTIVE COVERING, IT SHALL BE AS SPECIFIED IN CMUD SPECIFICATIONS FOR INSTALLATION OF BACKFLOW PREVENTION ASSEMBLIES.
4. FITTINGS SHALL BE AS SPECIFIED IN CMUD STANDARD SPECIFICATIONS.
5. TEST COCK # 1 SHALL BE UPSTREAM OF SHUT OFF VALVE # 1 AND IS PART OF THE APPROVED ASSEMBLY.
6. ABOVE GROUND INSTALLATIONS MUST BE LOCATED OUTSIDE ZONING SETBACK AREAS.

<b>CHARLOTTE-MECKLENBURG UTILITY DEPARTMENT ENGINEERING DIVISION CHARLOTTE, NORTH CAROLINA</b>					
<b>STANDARD DETAIL BACKFLOW PREVENTION</b>					
<b>REDUCE PRESSURE PRINCIPLE ASSEMBLY (RP)</b>					
<b>3/4" - 2"</b>					
Job No.	File No.	Scale	Drawn By	Project-Eng	Approved By
PLAN	NTS		J.S.	JAT	JAT
PROFILE	Hor.	Vert.			
As Built	Date				
Surveyed By	Designed By	Drawn By	Project-Eng	Approved By	Date
					6-3-94
					Sheet 1 of 12

No	Date	By	Reason
2	5/92	GG	GENERAL REVISIONS
1	6/91	JS	BY MBM COMMITTEE

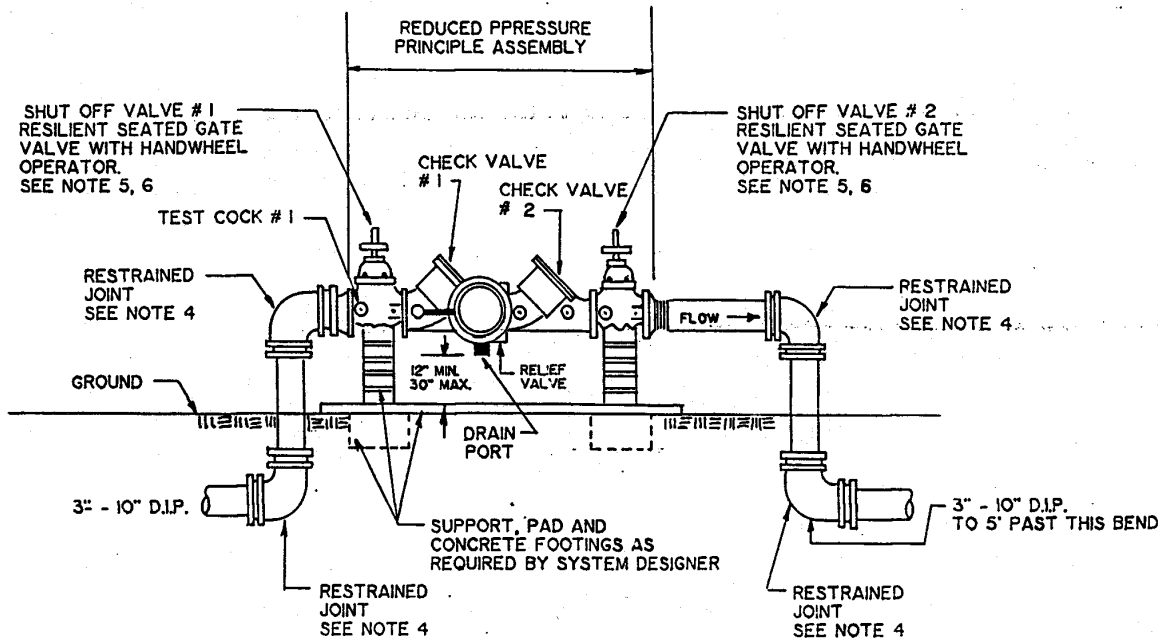

- NOTES:
1. REDUCED PRESSURE ASSEMBLIES (RP) MUST CONFORM TO CMUD SPECIFICATIONS.
  2. 8" - 10" RP SHALL BE SUPPORTED AT CENTER WITH BRICK PEDESTAL AND SHALL NOT BLOCK RELIEF VALVE ON DRAIN PORT.
  3. IF OUTDOOR INSTALLATION HAS PROTECTIVE COVERING IT SHALL BE AS SPECIFIED IN CMUD SPECIFICATIONS FOR INSTALLATION OF BACKFLOW PREVENTION ASSEMBLIES.
  4. RESTRAINED JOINTS SHALL BE WITH MEGA LUG RESTRAINTS, OR APPROVED EQUAL.
  5. THE CMUD APPROVED 3" - 10" RP INCLUDES SHUT OFF VALVES # 1 AND # 2, AS PART OF THE ASSEMBLY. NO SUBSTITUTIONS SHALL BE PERMITTED.
  6. FIRE LINE SERVICES SHALL HAVE OUTSIDE STEM AND YOKE (OS & Y) HANDWHEEL OPERATORS.
  7. TEST COCK # 1 SHALL BE UPSTREAM OF SHUT OFF VALVE # 1 AND IS PART OF THE APPROVED ASSEMBLY.
  8. ABOVE GROUND INSTALLATIONS MUST BE LOCATED OUTSIDE ZONING SETBACK AREAS.

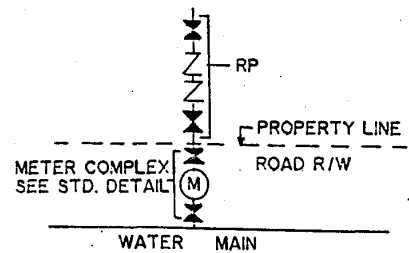

CHARLOTTE-MECKLENBURG  
UTILITY DEPARTMENT  
ENGINEERING DIVISION  
CHARLOTTE, NORTH CAROLINA

Job No. _____	File No. _____	STANDARD DETAIL BACKFLOW PREVENTION	
PLAN Scale: _____	PROFILES Hor: _____ Vert: _____	REDUCED PRESSURE PRINCIPLE ASSEMBLY (RP) 2-1/2" - 10"	
As Built _____	Date _____	J.S.	JAT
Drawn By _____	Designed By _____	JAT	5/30/81
Surveyed By _____	Checked By _____	Approved By _____	Date _____
		Sheet 2 of 12	

2	5/92	GG	GENERAL REVISIONS
1	6/91	JS	BY M&M COMMITTEE
No	Date	By	Revision

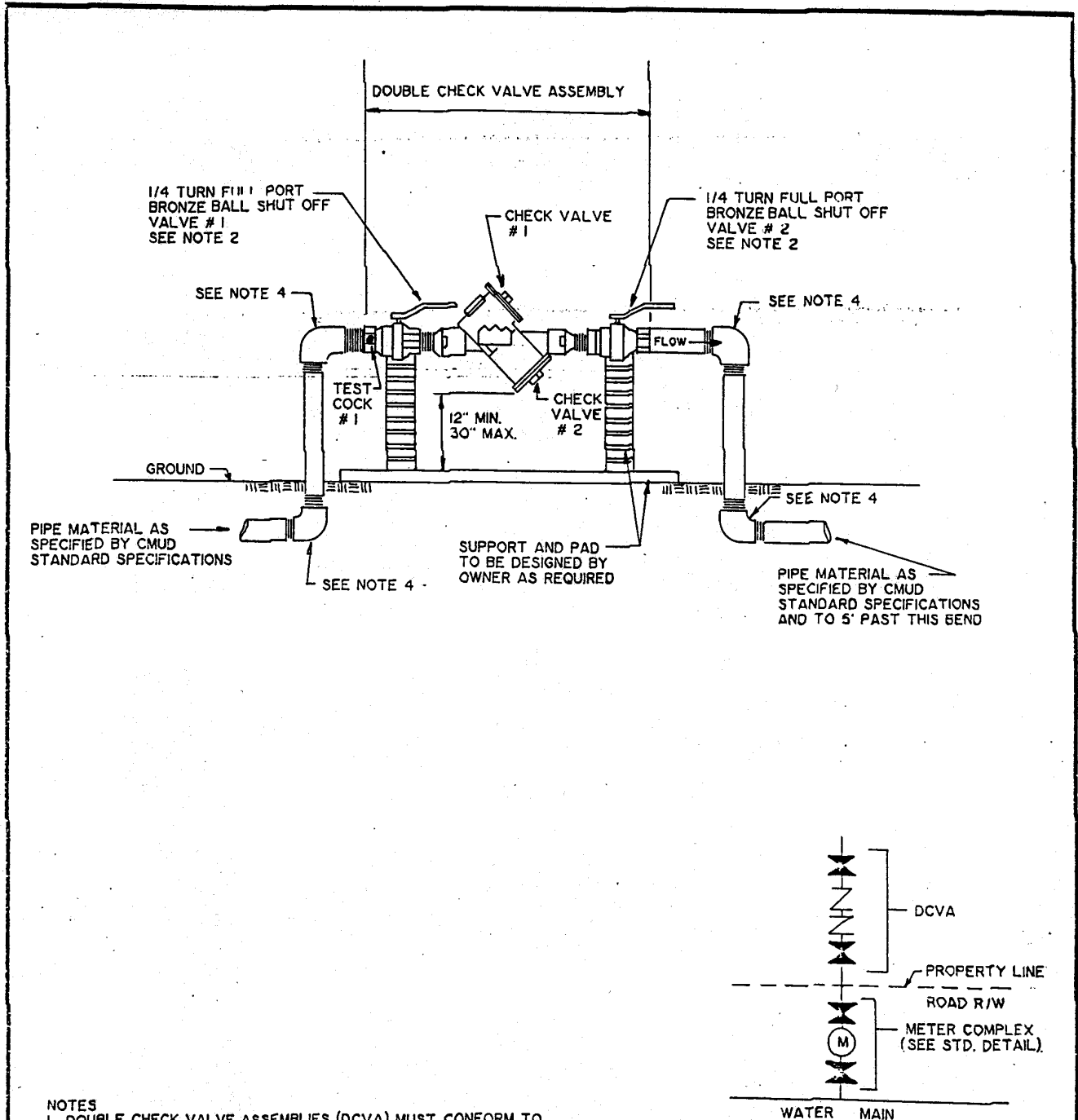

- NOTES**
1. DOUBLE CHECK VALVE ASSEMBLIES (DCVA) MUST CONFORM TO CMUD SPECIFICATIONS.
  2. THE CMUD APPROVED 3/4" - 2" DCVA INCLUDES SHUT OFF VALVES # 1 AND # 2 AS PART OF THE ASSEMBLY. NO SUBSTITUTIONS SHALL BE PERMITTED.
  3. IF OUTDOOR INSTALLATION HAS PROTECTIVE COVERING, IT SHALL BE AS SPECIFIED IN CMUD SPECIFICATIONS FOR INSTALLATION OF BACKFLOW PREVENTION ASSEMBLIES.
  4. FITTINGS SHALL BE AS SPECIFIED IN CMUD STANDARD SPECIFICATIONS.
  5. TEST COCK # 1 SHALL BE UPSTREAM OF SHUT OFF VALVE # 1 AND IS PART OF THE ASSEMBLY.
  6. ABOVE GROUND INSTALLATIONS MUST BE LOCATED OUTSIDE ZONING SETBACK AREAS.

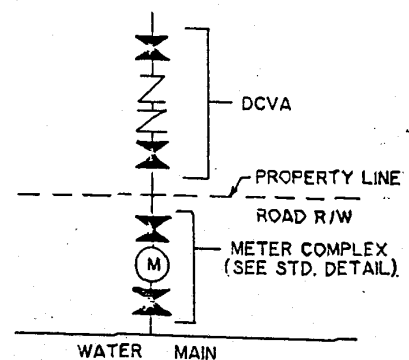

2	5/92	GG	GENERAL REVISIONS
1	6/91	JS	BY M&M COMMITTEE
No	Date	By	Reason

**CHARLOTTE-MECKLENBURG  
UTILITY DEPARTMENT  
ENGINEERING DIVISION  
CHARLOTTE, NORTH CAROLINA**

Job No. _____ File No. _____		<b>STANDARD DETAIL BACKFLOW PREVENTION</b>	
Series <u>N.T.S.</u>			
PLAN	_____	<b>DOUBLE CHECK VALVE ASSEMBLY (DCVA) 3/4" - 2" ABOVE GROUND</b>	
PROFILE	_____		
As Built	_____	_____	_____
Designed By	_____	Drawn By	_____
_____	_____	J.S.	JAT
_____	_____	Project-Engr	Approved By
_____	_____	Date	6/4/91
_____	_____	Sheet	3
_____	_____	Of	12

CUNGAN-PARNELL, INC., CHARLOTTE 487 704-372-7786

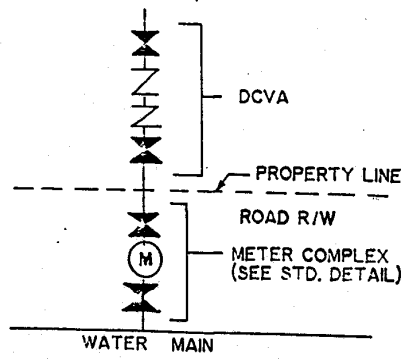
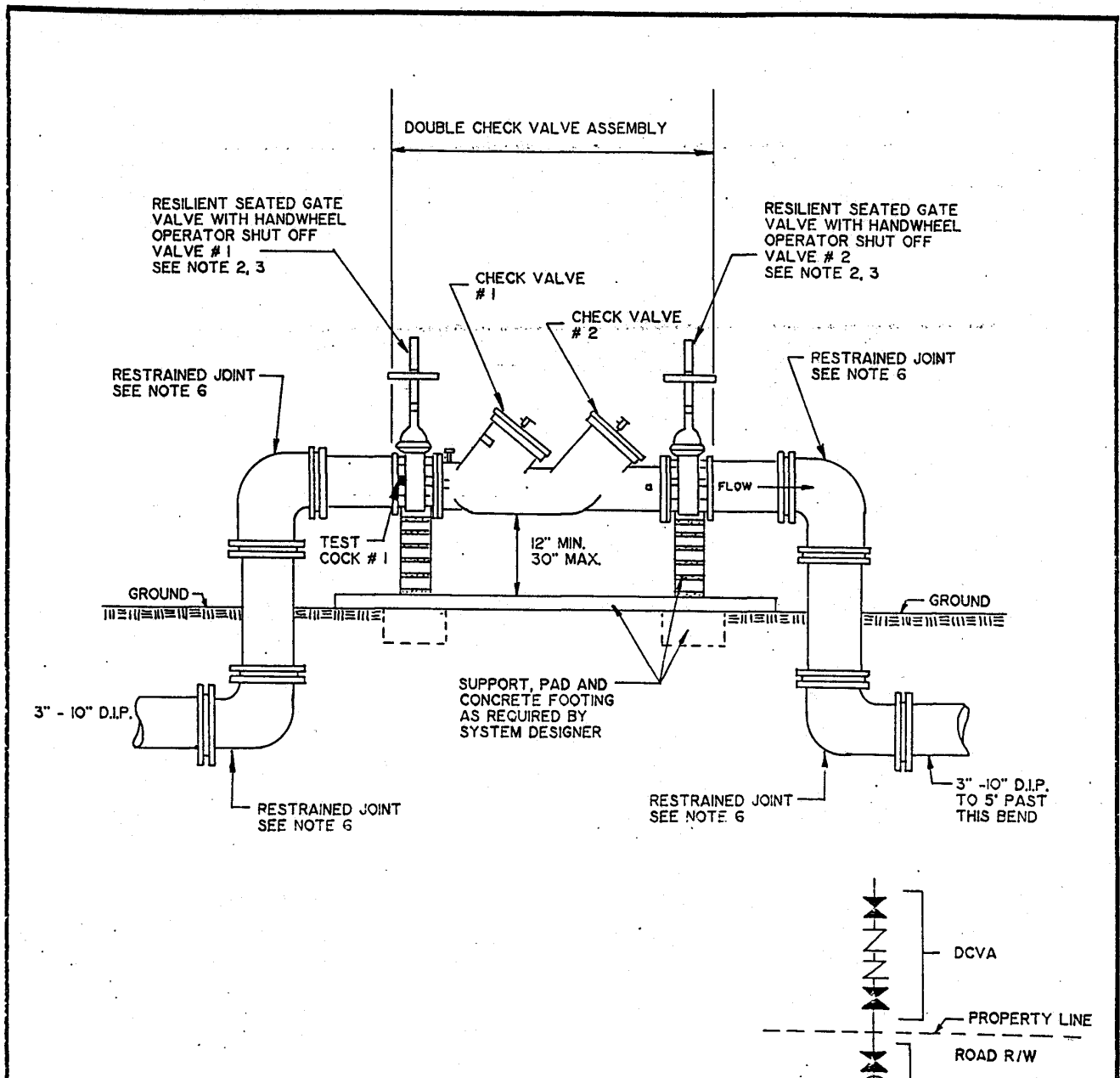

- NOTE
1. DOUBLE CHECK VALVE ASSEMBLIES (DCVA) MUST CONFORM TO CMUD SPECIFICATIONS.
  2. THE CMUD APPROVED DCVA INCLUDES SHUT OFF VALVES # 1 AND # 2 AS PART OF THE ASSEMBLY. NO SUBSTITUTIONS SHALL BE PERMITTED.
  3. FIRE LINE SERVICES SHALL HAVE OUTSIDE STEM AND YOKE (OS & Y) HANDWHEEL OPERATORS.
  4. 8" - 10" DCVA SHALL BE SUPPORTED AT CENTER WITH BRICK PEDESTAL.
  5. RESTRAINED JOINTS SHALL BE WITH MEGA LUG RESTRAINTS OR APPROVED EQUAL.
  6. TEST COCK # 1 SHALL BE UPST REAM OF SHUT OFF VALVE # 1 AND IS PART OF THE APPROVED ASSEMBLY.
  7. IF OUTDOOR INSTALLATION HAS PROTECTIVE COVERING, IT SHALL BE AS SPECIFIED IN CMUD SPECIFICATIONS FOR INSTALLATION OF BACKFLOW PREVENTION ASSEMBLIES.
  8. ABOVE GROUND INSTALLATIONS MUST BE LOCATED OUTSIDE ZONING SETBACK AREAS.

2	5/92	GG	GENERAL REVISIONS
1	6/91	JS	BY M&M COMMITTEE
No	Date	By	Revision

**CHARLOTTE-MECKLENBURG  
UTILITY DEPARTMENT  
ENGINEERING DIVISION  
CHARLOTTE, NORTH CAROLINA**

**STANDARD DETAIL  
BACKFLOW PREVENTION**

**DOUBLE CHECK VALVE ASSEMBLY  
(DCVA) 2-1/2" - 10" ABOVE GROUND**

Job No.	File No.	Scale	N.T.S.	
PLAN				
PROFILE	Hor	Vert		
As	By	Date		
Surveyed By	Designed By	Drawn By	Project-Engr	Approved By
		JS	JAT	JAT
		6/4/91		
				Sheet 4 of 12

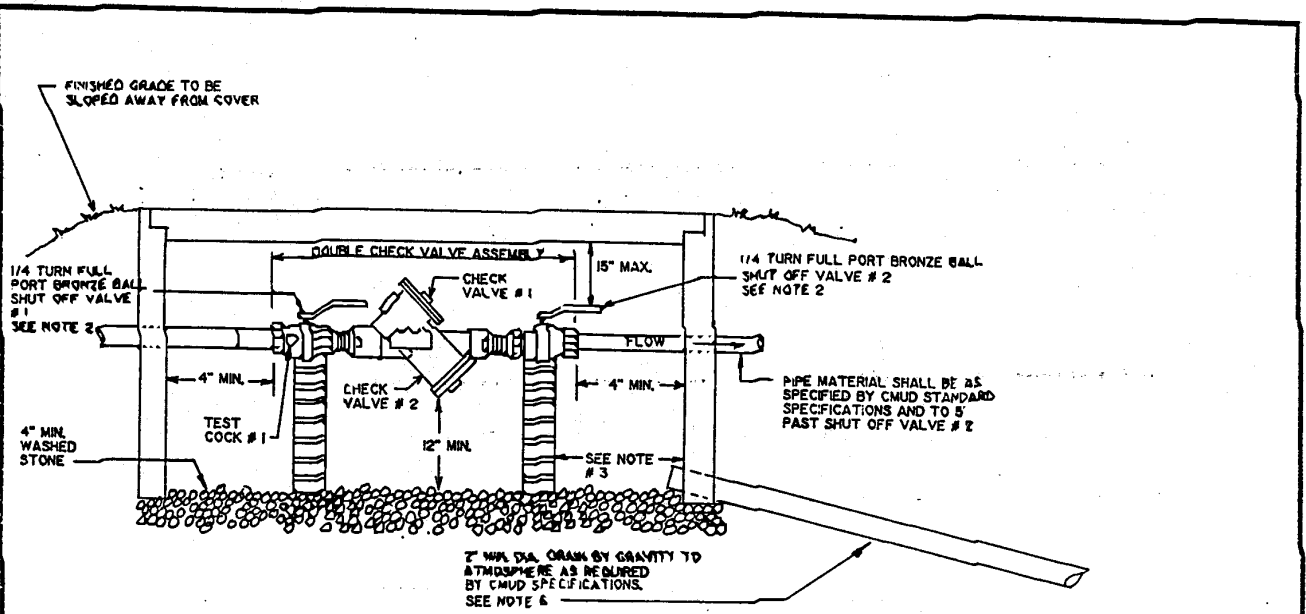

**ELEVATION VIEW**

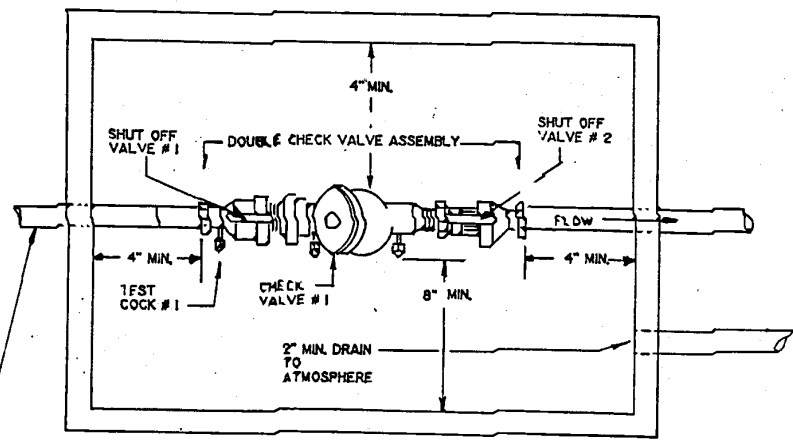

**PLAN VIEW**

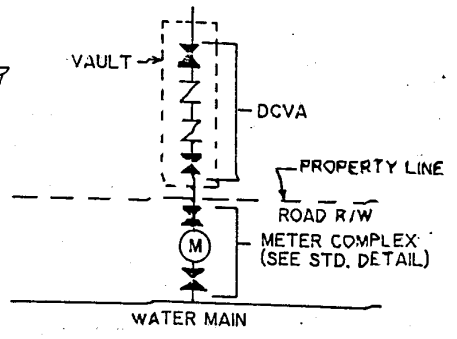

- NOTES:
1. DCVA MUST CONFORM TO CMUD SPECIFICATIONS FOR BACKFLOW PREVENTION ASSEMBLIES 3/4" & 1".
  2. CMUD APPROVED DCVA'S INCLUDE SHUT OFF VALVE # 1 AND # 2. NO SUBSTITUTIONS SHALL BE PERMITTED.
  3. VAULT, DOORS OR COVERS AND SUPPORT OF ASSEMBLY SHALL BE DESIGNED BY OWNER AND AS REQUIRED.
  4. IF DRAINAGE CANNOT BE PROVIDED TO FREE ATMOSPHERE OR STORM DRAINAGE, THE DCVA'S SHALL BE INSTALLED ABOVE GROUND.
  5. TEST COCK # 1 SHALL BE UPSTREAM OF SHUT OFF VALVE # 1 AND IS PART OF THE APPROVED ASSEMBLY. ALL TEST COCKS MUST BE ON ONE SIDE OR TOP. ASSEMBLIES SHALL BE INSTALLED UPRIGHT AND IN THE HORIZONTAL POSITION.
  6. DRAIN MAY BE PROVIDED AS SHOWN OR AS FLOOR DRAIN.

2	6/92	GG	GENERAL REVISIONS
1	6/91	JS	BY MBM COMMITTEE

**CHARLOTTE-MECKLENBURG  
UTILITY DEPARTMENT  
ENGINEERING DIVISION  
CHARLOTTE, NORTH CAROLINA**

---

**STANDARD DETAIL  
BACKFLOW PREVENTION**

**DOUBLE CHECK VALVE ASSEMBLY  
(DCVA) 3/4" & 1" VAULT**

Job No.	File No.	Scale		
PLAN		N.T.S.		
PROJECT	No.	Date		
Dr.	Rev.	Date		
Checked By	Designed By	Drawn By	Project-Eng.	Approved By
		J.S.	JAT	JAT
		5/20/94		
			5	12

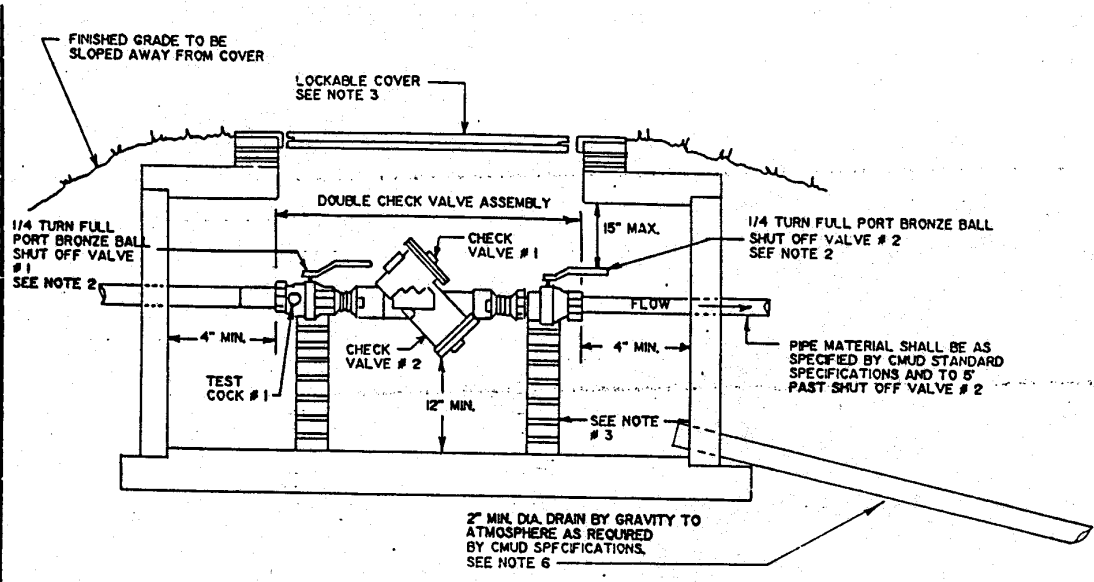

**ELEVATION VIEW**

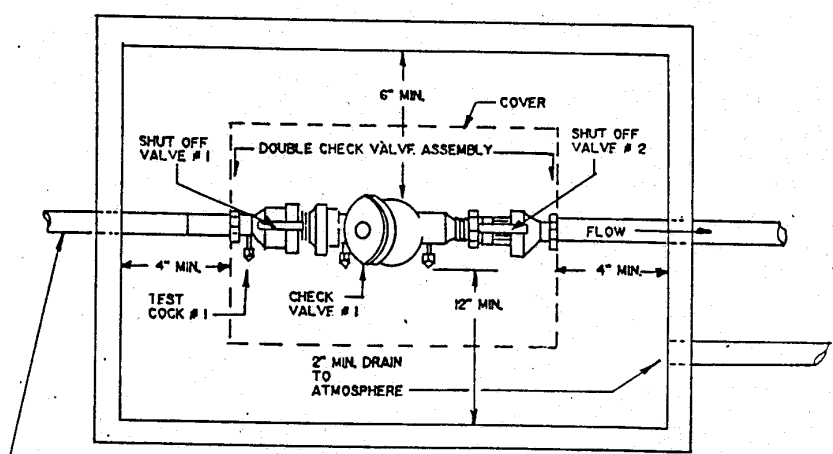

**PLAN VIEW**

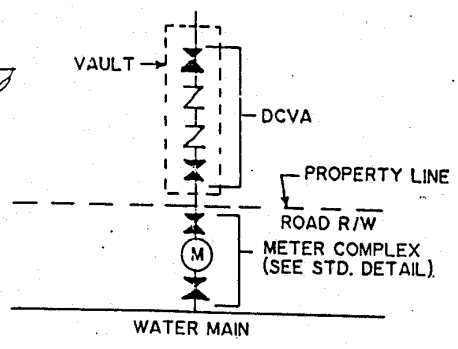

- NOTES:
1. DCVA MUST CONFORM TO CMUD SPECIFICATIONS FOR BACKFLOW PREVENTION ASSEMBLIES 1-1/2" & 2".
  2. CMUD APPROVED DCVA'S INCLUDE SHUT OFF VALVE # 1 AND # 2. NO SUBSTITUTIONS SHALL BE PERMITTED.
  3. VAULT, DOORS OR COVERS AND SUPPORT OF ASSEMBLY SHALL BE DESIGNED BY OWNER AND AS REQUIRED.
  4. IF DRAINAGE CANNOT BE PROVIDED TO FREE ATMOSPHERE OR STORM DRAINAGE, THE DCVA'S SHALL BE INSTALLED ABOVE GROUND.
  5. TEST COCK # 1 SHALL BE UPSTREAM OF SHUT OFF VALVE # 1 AND IS PART OF THE APPROVED ASSEMBLY. ALL TEST COCKS MUST BE ON ONE SIDE OR TOP. ASSEMBLIES SHALL BE INSTALLED UPRIGHT AND IN THE HORIZONTAL POSITION.
  6. DRAIN MAY BE PROVIDED AS SHOWN OR AS FLOOR DRAIN.

**CHARLOTTE-MECKLENBURG  
UTILITY DEPARTMENT  
ENGINEERING DIVISION  
CHARLOTTE, NORTH CAROLINA**

STANDARD DETAIL BACKFLOW PREVENTION	
DOUBLE CHECK VALVE ASSEMBLY (DCVA) 1-1/2" & 2" VAULT	
Job No. _____ File No. _____	Scale: <u>N.T.S.</u>
PLAN _____	PROFILE _____
As Built _____	Date _____
Survived By _____	Designed By _____
Drawn By <u>J.S.</u>	Project-Eng. <u>JAT</u>
Approved By <u>JAT</u>	Date <u>5/30/94</u>
Sheet <u>6</u>	Of <u>12</u>

No.	Date	By	Revision
2	5/92	GG	GENERAL REVISIONS
1	6/91	JS	BY MBM COMMITTEE

CUNGAN-PARNELL, INC., CHARLOTTE 487 704-372-7788

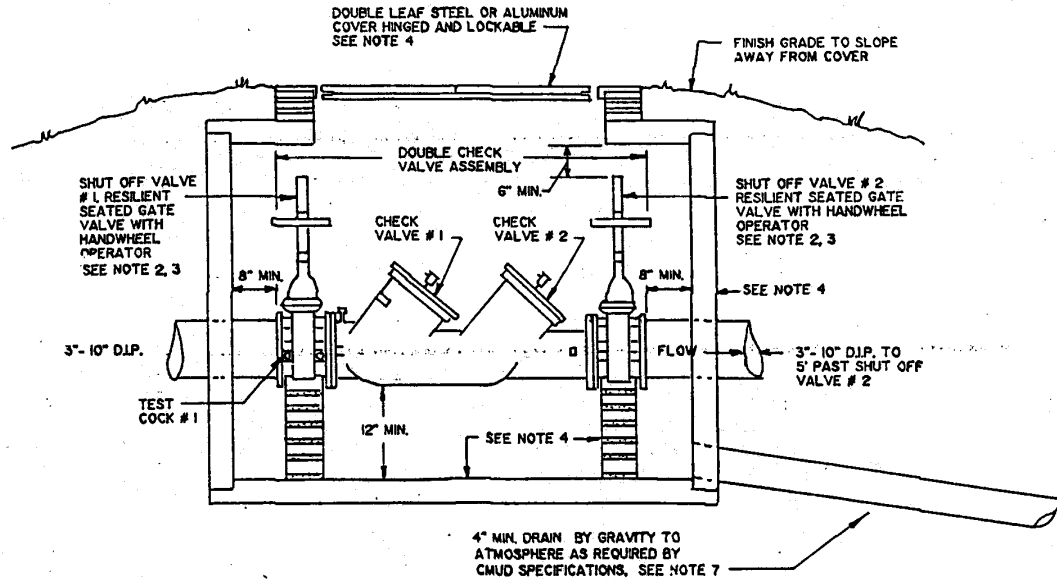

**ELEVATION**

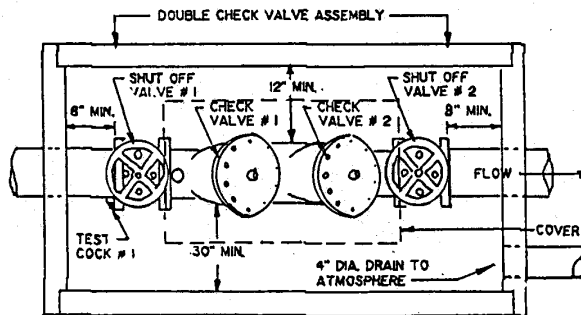

**PLAN**

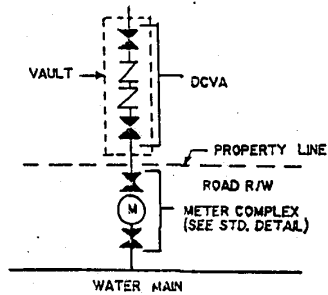

- NOTES:
1. DCVA'S MUST CONFORM TO CMUD SPECIFICATIONS.
  2. CMUD APPROVED DCVA INCLUDES SHUT OFF VALVES # 1 AND # 2 AS PART OF THE UNIT. NO SUBSTITUTIONS SHALL BE PERMITTED. 6" CLEARANCE SHALL BE WITH VALVE OPEN.
  3. FIRE LINE INSTALLATIONS SHALL HAVE OUTSIDE STEM AND YOKE (OS&Y) HANDWHEEL OPERATORS.
  4. VAULT, DOORS OR COVERS AND SUPPORT OF ASSEMBLY... SHALL BE DESIGNED BY OWNER AS REQUIRED.
  5. TEST COCK # 1 SHALL BE UPSTREAM OF SHUT OFF VALVE # 1 AND IS PART OF ASSEMBLY.
  6. IF DRAINAGE CANNOT BE PROVIDED TO FREE ATMOSPHERE OR STORM DRAINAGE, THE DCVA SHALL BE INSTALLED ABOVE GROUND.
  7. DRAINAGE MAY BE PROVIDED AS SHOWN OR AS FLOOR DRAIN.

**CHARLOTTE-MECKLENBURG  
UTILITY DEPARTMENT  
ENGINEERING DIVISION  
CHARLOTTE, NORTH CAROLINA**

Job No. _____ File No. _____		<b>STANDARD DETAIL BACKFLOW PREVENTION</b>					
PLAN	Scale N.T.S.						
PROFILE	Vert. _____	<b>DOUBLE CHECK VALVE ASSEMBLY (DCVA) 2-1/2" - 10" VAULT</b>					
As Built	Date _____						
Drawn By	Designed By	JS	JAT	JAT	5/30/97	Sheet	Of
						17	12

No.	Date	By	Revision
2	5/92	GG	GENERAL REVISIONS
1	6/91	JS	BY M&M COMMITTEE

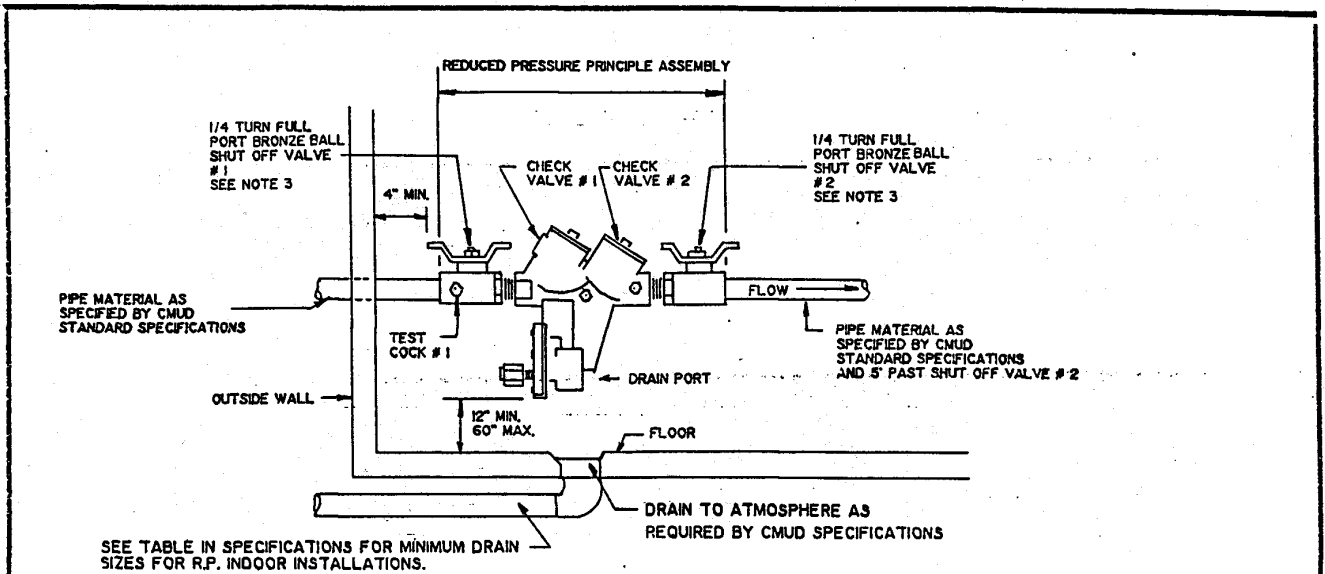

ELEVATION VIEW

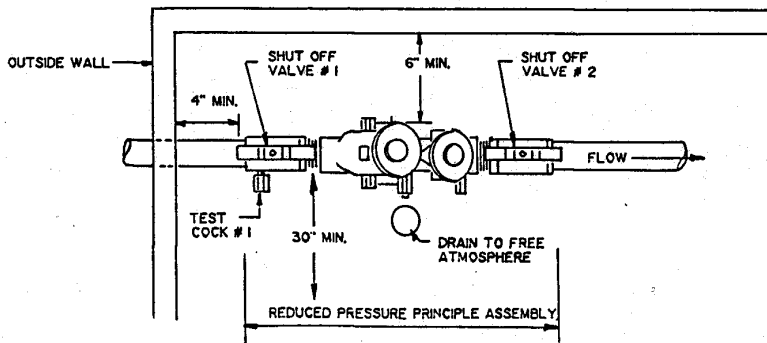

PLAN VIEW

NOTES:

1. INDOOR INSTALLATION SHALL ONLY BE PERMITTED IN CASES WHERE ADEQUATE SPACE FOR THE BACKFLOW PREVENTION ASSEMBLY IS NOT AVAILABLE OUTSIDE. CMUD SHALL REVIEW ON A CASE BY CASE BASIS.
2. THE 3/4" - 2" RP MUST CONFORM TO CMUD STANDARDS FOR BACKFLOW PREVENTION ASSEMBLIES.
3. CMUD APPROVED 3/4" - 2" RP INCLUDES SHUT OFF VALVES # 1 AND # 2 AS PART OF THE ASSEMBLY. NO SUBSTITUTIONS SHALL BE PERMITTED.
4. SUPPORT FOR ASSEMBLY SHALL BE DESIGNED BY OWNER AS REQUIRED.
5. AN AIR-GAP DRAIN IS RECOMMENDED TO REDUCE SPLASHING OF MINOR DISCHARGES FROM THE RELIEF VALVE DRAIN PORT.
6. TEST COCK # 1 SHALL BE UPSTREAM OF SHUT OFF VALVE # 1 AND IS PART OF THE APPROVED ASSEMBLY ALL TEST COCKS MUST BE ON ONESIDE OR TOP. ASSEMBLIES SHALL BE INSTALLED UPRIGHT AND IN THE HORIZONTAL POSITION.

<b>CHARLOTTE-MECKLENBURG UTILITY DEPARTMENT ENGINEERING DIVISION CHARLOTTE, NORTH CAROLINA</b>			
Job No. _____ File No. _____		<b>STANDARD DETAIL BACKFLOW PREVENTION</b>	
PLAN Scale <u>N.T.S.</u>		<b>REDUCED PRESSURE PRINCIPLE ASSEMBLY (RP) 3/4" - 2" INDOOR</b>	
PROFILE Hor _____ Vert _____			
As Built Date _____		Drawn By <u>J.S.</u>	Project-Eng <u>JAT</u>
Succeeded By _____		Designed By _____	Approved By <u>JAT</u>
		6-3-91	Sheet 8 of 12

2	5/92	TR	GENERAL REVISION
1	6/91	J.S.	BY M&M COMMITTEE
No.	Date	By	Revision



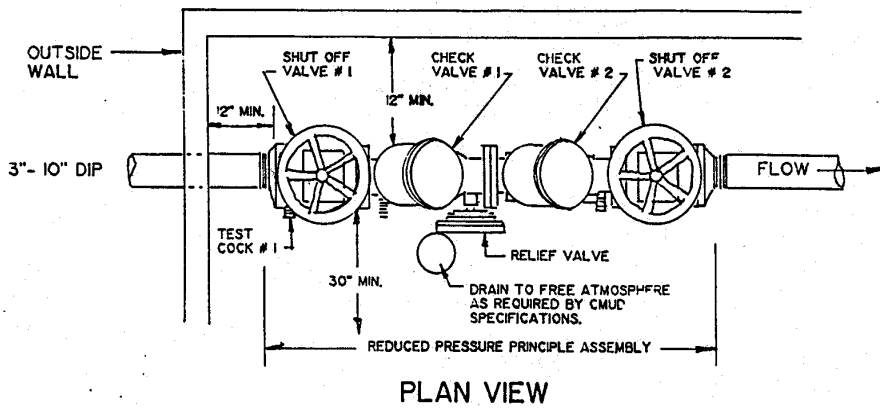
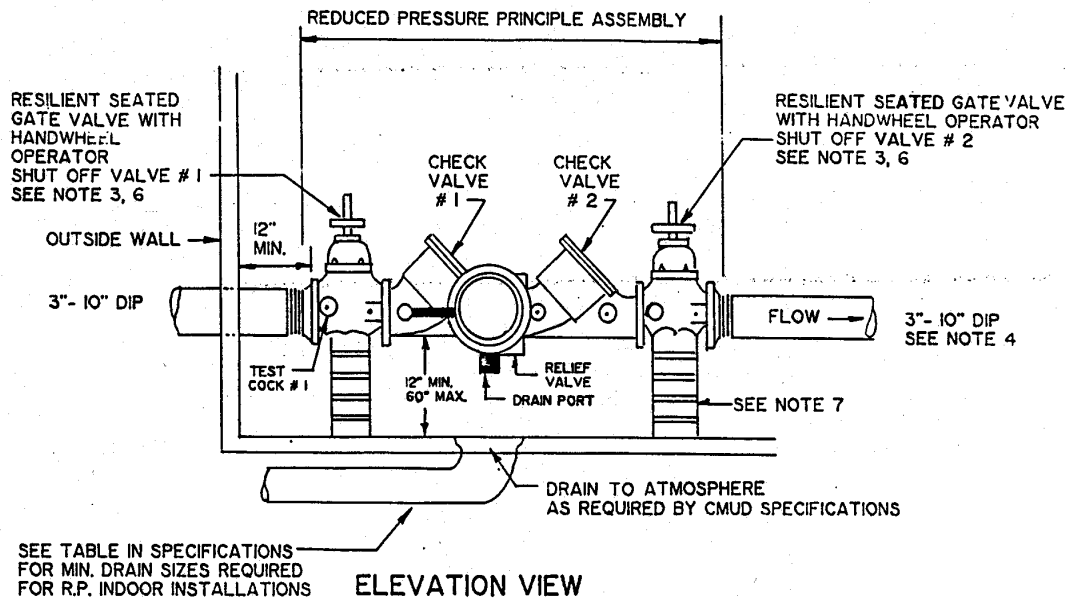

**NOTES:**

1. INDOOR INSTALLATIONS SHALL ONLY BE PERMITTED IN CASES WHERE ADEQUATE SPACE FOR THE BACKFLOW PREVENTION ASSEMBLY IS NOT AVAILABLE OUTSIDE. CMUD SHALL REVIEW ON A CASE BY CASE BASIS.
2. REDUCED PRESSURE ASSEMBLIES (RP) MUST CONFORM TO CMUD SPECIFICATIONS.
3. THE CMUD APPROVED 3"- 10" RP INCLUDES SHUT OFF VALVE # 1 AND # 2. NO SUBSTITUTIONS SHALL BE PERMITTED.
4. ALL PIPE 3"- 10" SHALL BE DIP FROM THE TAP AT THE MAIN TO 5' PAST SHUT OFF VALVE # 2.
5. RESTRAINED JOINTS SHALL BE WITH MEGA LUG RESTRAINTS, OR APPROVED EQUAL.
6. FIRE LINE INSTALLATIONS SHALL HAVE OUTSIDE STEM AND YOKE (OS & Y) HANDWHEEL OPERATOR.
7. SUPPORT OF 3"- 10" RP SHALL BE DESIGNED BY OWNER. IT IS RECOMMENDED 8"- 10" RP BE SUPPORTED AT CENTER. THE SUPPORT SHALL NOT BLOCK RELIEF VALVE OR DRAIN PORT.
8. TEST COCK # 1 SHALL BE UPSTREAM OF SHUT OFF VALVE # 1 AND IS PART OF THE APPROVED ASSEMBLY.
9. AN AIR-GAP DRAIN IS RECOMMENDED TO REDUCE SPLASHING OF MINOR DISCHARGE FROM THE RELIEF VALVE DRAIN PORT.

2	5/92	GG	GENERAL REVISIONS
1	7/91	J.S.	BY M&M COMMITTEE

<b>CHARLOTTE-MECKLENBURG UTILITY DEPARTMENT ENGINEERING DIVISION CHARLOTTE, NORTH CAROLINA</b>					
Job No. _____			File No. _____		
PLAN			Scale: <b>N.T.S.</b>		
PROFILE			Hor. _____ Vert. _____		
At _____			Date _____		
Surveyed By		Designed By		Drawn By	
JS		JAT		JAT	
Project-Eng.		Approved By		Date	
				6-3-91	Sheet 9 of 12

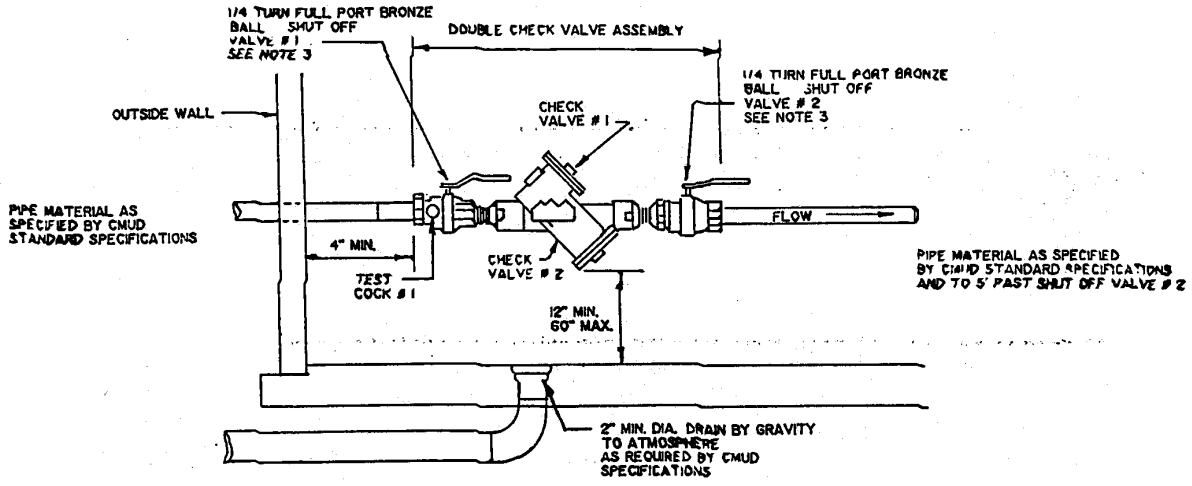

ELEVATION VIEW

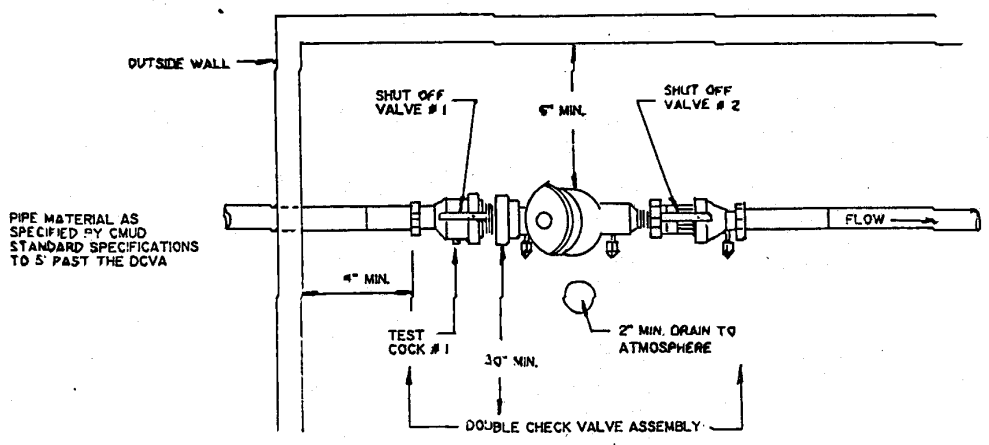

PLAN VIEW

- NOTES:
1. INDOOR INSTALLATION SHALL ONLY BE PERMITTED IN CASES WHERE ADEQUATE SPACE FOR THE BACKFLOW PREVENTION ASSEMBLY IS NOT AVAILABLE OUTSIDE. CMUD WILL REVIEW ON A CASE BY CASE BASIS.
  2. DCVA MUST CONFORM TO CMUD SPECIFICATIONS FOR BACKFLOW PREVENTION ASSEMBLIES 3/4"- 2".
  3. CMUD APPROVED DCVA INCLUDES SHUT OFF VALVES # 1 AND # 2 AS PART OF THE ASSEMBLY. NO SUBSTITUTIONS SHALL BE PERMITTED.
  4. SUPPORT OF BACKFLOW PREVENTION ASSEMBLY SHALL BE DESIGNED BY OWNER AS REQUIRED.
  5. TEST COCK # 1 SHALL BE UPSTREAM OF SHUT OFF VALVE # 1 AND IS PART OF THE ASSEMBLY.

**CHARLOTTE-MECKLENBURG  
UTILITY DEPARTMENT  
ENGINEERING DIVISION  
CHARLOTTE, NORTH CAROLINA**

Job No. _____ File No. _____		<b>STANDARD DETAIL BACKFLOW PREVENTION</b>					
Scale: <b>N.T.S.</b>							
PLAN	NO. OF 11	<b>DOUBLE CHECK VALVE ASSEMBLY (DCVA) 3/4"- 2" INDOOR</b>					
DATE	YEAR						
As Built	Date						
Surveyed By	Designed By	JS	JAT	JAT	6-4-91	Sheet	Of
		Drawn By	Project-Engr	Approved By	Date	10	12

2	5/92	GG	GENERAL REVISIONS
1	7/91	JS	BY M&M COMMITTEE

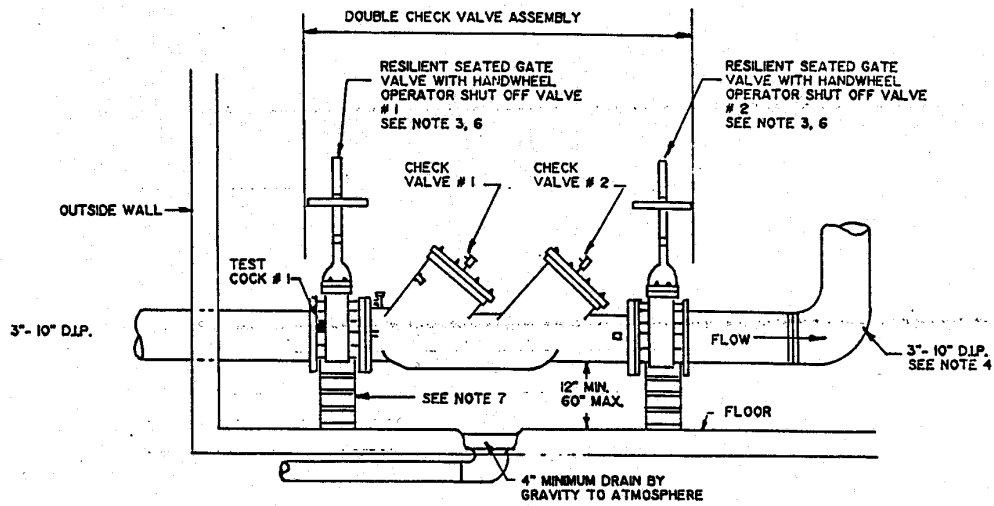

ELEVATION VIEW

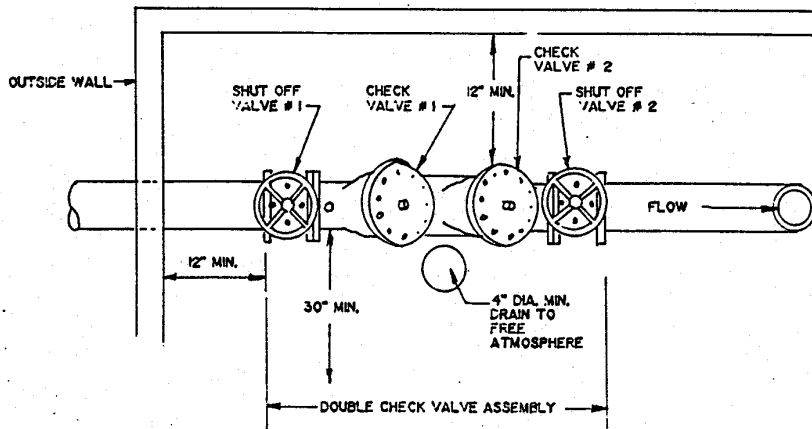

PLAN VIEW

NOTES:

1. INDOOR INSTALLATIONS SHALL ONLY BE PERMITTED IN CASES WHERE ADEQUATE SPACE IS NOT AVAILABLE OUTSIDE. CMUD WILL REVIEW THESE ON A CASE BY CASE BASIS.
2. DCVA MUST CONFORM TO CMUD SPECIFICATIONS.
3. CMUD APPROVED DCVA INCLUDES SHUT OFF VALVES # 1 AND # 2 AS PART OF THE ASSEMBLY. NO SUBSTITUTIONS SHALL BE PERMITTED.
4. ALL PIPE 3'- 10" SHALL BE D.I.P. FROM THE TAP AT THE MAIN TO 5' PAST THE SHUT OFF VALVE # 2
5. RESTRAINED JOINTS SHALL BE WITH MEGA LUG RESTRAINTS OR APPROVED EQUAL.
6. FIRE LINE INSTALLATIONS SHALL HAVE OUTSIDE STEM AND YOKE (OS & Y) HANDWHEEL OPERATORS.
7. SUPPORT OF 3'- 10" DCVA SHALL BE DESIGNED BY OWNER. IT IS RECOMMENDED 8'- 10" DCVA BE SUPPORTED AT CENTER.
8. TEST COCK # 1 SHALL BE UPSTREAM OF SHUT OFF VALVE # 1 AND IS PART OF THE APPROVED ASSEMBLY.

CHARLOTTE-MECKLENBURG  
UTILITY DEPARTMENT  
ENGINEERING DIVISION  
CHARLOTTE, NORTH CAROLINA

Job No. _____	File No. _____	STANDARD DETAIL BACKFLOW PREVENTION			
PLAN _____	Scale N.T.S.				
PROFILE _____	Hor _____	DOUBLE CHECK VALVE ASSEMBLY (DCVA) 2 1/2" - 10" INDOOR			
As Built _____	Date _____				
Drawn By JS	Project-Eng JAT	JAT	S-SL:91	Sheet 11	Of 12
Designed By _____	Approved By _____	Date _____			

No.	Date	By	Revision
2	5/92	TR	GENERAL REVISION
1	7/91	JS	BY M&M COMMITTEE

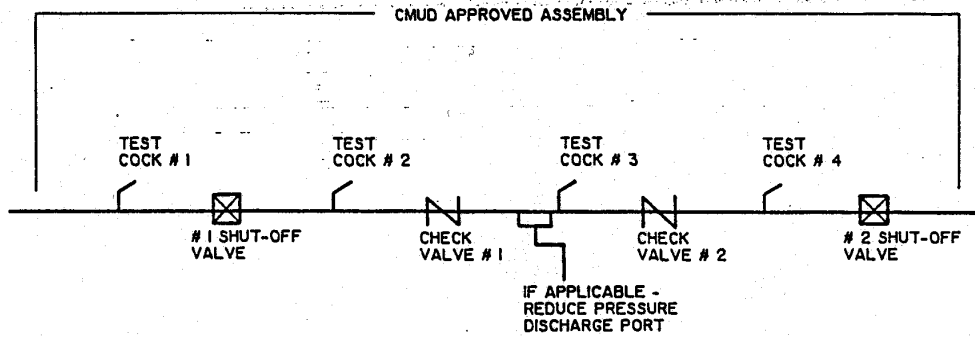

Flow  
→

<b>CHARLOTTE-MECKLENBURG UTILITY DEPARTMENT ENGINEERING DIVISION CHARLOTTE, NORTH CAROLINA</b>			
Job No. _____ File No. _____		<b>STANDARD DETAIL BACKFLOW PREVENTION</b>	
PLAN _____ PROFILE _____		<b>TEST COCK LOCATION</b>	
As Built _____ Date _____			
Surveyed By _____	Designed By _____	TAR _____ JAT _____ JAT _____	5/92 _____
No. _____	Date _____	Drawn By _____	Project-Engr _____
By _____	Revision _____	Approved By _____	Date _____
		Sheet 12	Of 12